

SPECIFICATION SHEET

SPECIFICATION SHEET NO.	Q0522-FK10M70000SVA5
DATE	May 22, 2023
REVISION	A0
DESCRIPTION	SMD MHz Ceramic Filter, L7.0*W3.0*H1.5mm, 3 Pads, CF73 Series 10.700MHz 3dB Band Width kHz: 280+/-50KHz, Insertion Loss: 3.0+/-2.0dB. Impedance: 330 ohm Operating Temp. Range -20°C ~+80°C, Packed in Tape/Reel, 4000pcs/Reel RoHS/RoHS III compliant
CUSTOMER	
CUSTOMER PART NUMBER	
CROSS REF. PART NUMBER	
ORIGINAL PART NUMBER	TGS CF73 10.7MVA5 TLF
PART CODE	FK10M70000SVA5

VENDOR APPROVE

Issued/Checked/Approved



DATE: May 22, 2023

CUSTOMER APPROVE

DATE:

5/24/2023

SMD MHZ CERAMIC FILTER CF73 SERIES VA5 TYPE

MAIN FEATURE

- SMD MHz Ceramic Filter, L7.0*W3.0*H1.5mm, 3 Pads
- Low cost & short lead time.
- Cross more competitors part SFECF/SFECV Series
- RoHS/RoHS III compliant



APPLICATION

- Communication Electronics and more

PART CODE GUIDE

RFQ
[Request For Quotation](#)

FK	10M70000	S	VA5
1	2	3	4

- 1) FK: Part family Code for SMD MHz Ceramic Filter, L7.0*W3.0*H1.5mm, 3 Pads, CF73 series
- 2) 10M70000: Frequency range code for 10.70000MHz
- 3) S: Packed in Tape/Reel
- 4) VA5: Specification code for original Part No. TGS CF73 10.7MVA5 TLF

SMD MHZ CERAMIC FILTER CF73 SERIES VA5 TYPE

DIMENSION (Unit: mm)

Image for reference

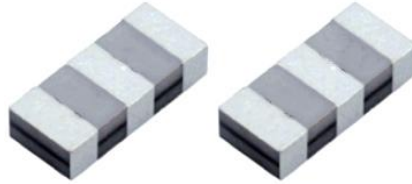

CF73

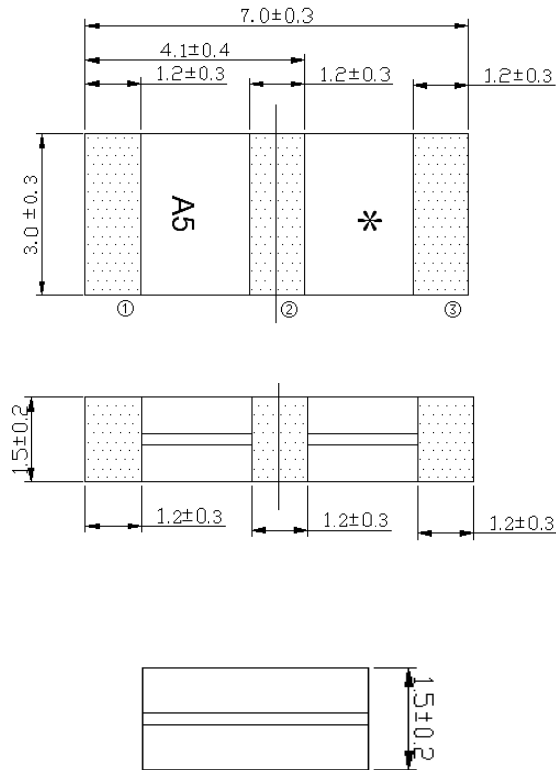

*: QC Code

(1): Input

(2): Ground

(3): Output

Structure

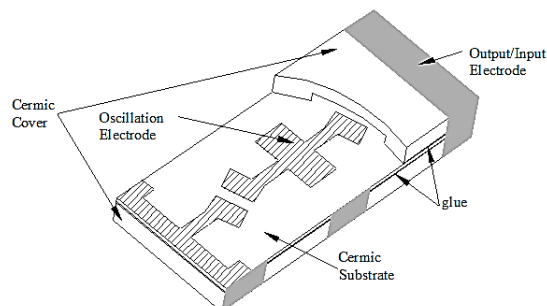

SMD MHZ CERAMIC FILTER CF73 SERIES VA5 TYPE
ELECTRICAL PARAMETERS

Parameter	Part No. Symbol	Units	Value			Condition
			Min.	Typical	Max.	
Original Manufacturer	TGS	TGS Crystals				
Holder Type	CF73	SMD MHz Ceramic Filter, L7.0*W3.0*H1.5mm, 3 Pads				
Center Frequency (f0)	10.7M	MHz	10.7000		@+/-30KHz	
Bandwidth	VA5	kHz	230	280	330	@3 dB
Bandwidth		kHz	-		590	@20 dB
Ripple		dB			1.0	within 3dB bandwidth
Insertion Loss		dB	1.0	3.0	5.0	@Min.loss point
Temp. Characteristic		%			±0.5	@-20°C ~ +80°C
Spurious Response		dB	35			@9.0 ~ 12.0MHz
Input/Output Impedance		Ω		330		
Insulation Resistance		MΩ	100			@ 10V 1 min.
Withstand DC Voltage		V			50	@ DC, 1 min
Operating Temp. Range		°C	-20		+80	
Storage Temp. Range	°C	-40		+85		
Others	Package	T	Packed in Tape/Reel			
	RoHS Status	LF	RoHS III compliant			
	Add Value		N/A			
	Internal Control Code *		N/A			

 Note: Original Part Number: **TGS CF73 10.7MVA5 TLF**

SMD MHZ CERAMIC FILTER CF73 SERIES VA5 TYPE

RELIABILITY

Test Items	Test Method And Conditions	Requirement
Humidity	After being placed in a chamber with 90-95% R.H. at 40±2°C for 96 hours and then being placed in room temperature for 1 hour, filter shall be measured.	It shall fulfill Table 1.
High Temperature	After being placed in a chamber with 85±2 °C,for 96 hours and then being placed in room temperature for 1 hour, filter shall be measured.	It shall fulfill Table 1.
Low Temperature	After being placed in a chamber with -40±2 °C,for 96 hours and then being placed in room temperature for 1 hour, filter shall be measured.	It shall fulfill Table 1.
Temperature Cycling	After temperature cycling of blow table was performed 5 times, Filter shall be measured after being placed in natural conditions for 1h. Temp.: -20±3°C, Time: 30±3 min ; Temp.: -80±3°C, Time: 30±3 min.	It shall fulfill Table 1.
Vibration	Subject the filter to vibration for 2h.Each in x y and z axis with the amplitude of 1.5mm, The frequency shall be varied uniformly between the limits of 10Hz-55Hz-10Hz and then filter shall be measured.	It shall fulfill Table 1.
Mechanical Shock	Filter shall be measured after 3 times random dropping from the height of 1m on the wooden plate.	No visible damage. it shall fulfill Table 1
Soldering Test	Passed through the reflow oven under the following condition, and left at room temp. for 24 hours before measurement.	It shall fulfill Table 1.
Solderability	Dipped in 235°C±5°C solder bath for 3s±0.5s with rosin flux (25wt% ethanol solution.)	The terminals shall be at least 95% covered by solder.
Board Bending	Mount on a glass-epoxy board(width =50mm, thickness=1.6mm),then bend it to 1mm displacement(velocity= 1mm/s) and keep it for 5s.	Mechanical damage such as break shall not occur

SMD MHZ CERAMIC FILTER CF73 SERIES VA5 TYPE

Table 1

Test Items	Characteristics after test
Center Frequency Drift	±30 kHz Max.
Insertion Loss Drift	±2.0 dB Max.
3dB Bandwidth Drift	±25 kHz Max.
20dB Bandwidth Drift	±60 kHz Max.
Note: The limits in the above table are referenced to the initial measurements.	

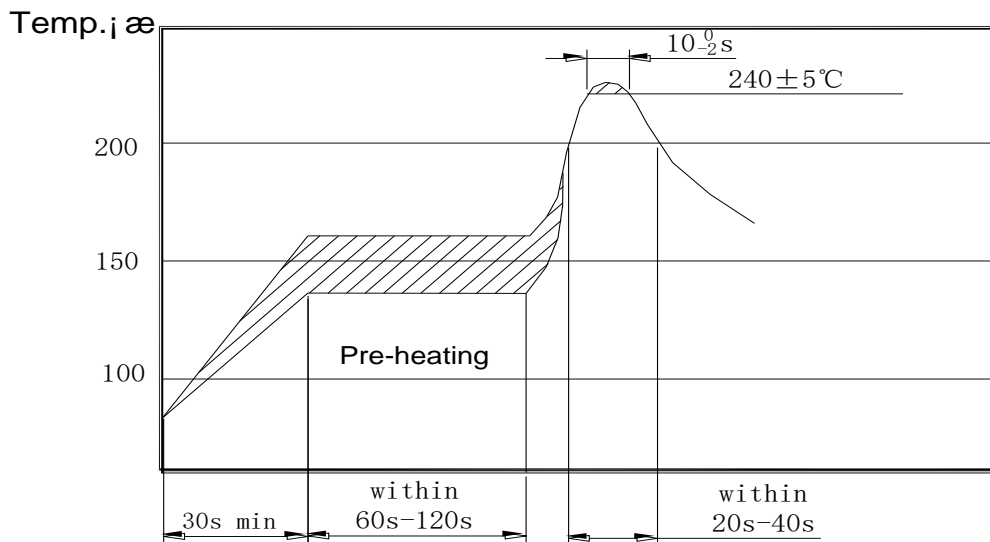

Soldering Test

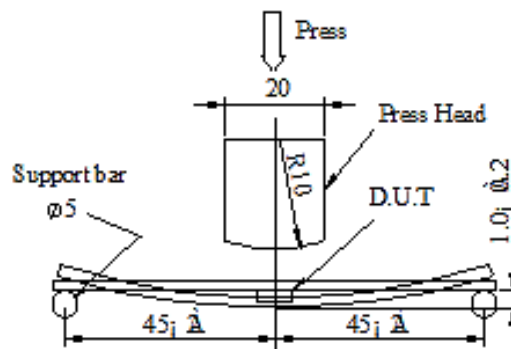

Board Bending

SMD MHZ CERAMIC FILTER CF73 SERIES VA5 TYPE

TEST CIRCUIT (For Reference Only)

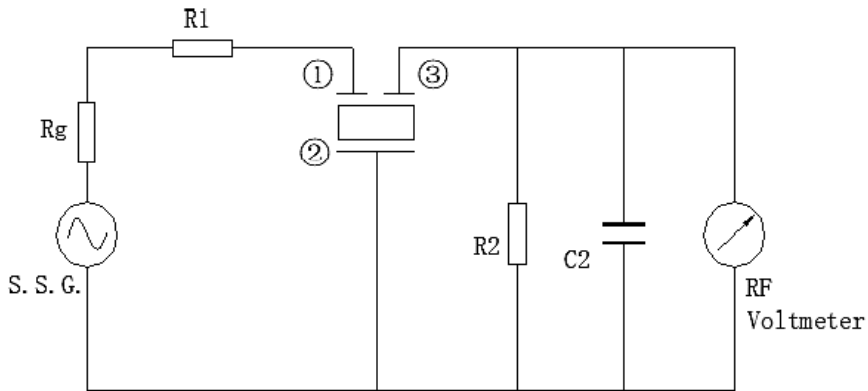

$$R1+Rg = R2=330\Omega\pm5\%, Rg=50\Omega$$

C2=10 PF (Including stray capacitance and capacitance of RF Voltmeter)

S.S.G.:Output Voltmeter

(1): Input (2): Ground (3): Output

Note:

Parts shall be tested under the condition (Temp.: $20\pm15^{\circ}\text{C}$, Humidity $65\pm20\%$ R.H.) unless the standard condition (Temp.: $25\pm3^{\circ}\text{C}$, Humidity : $65\pm10\%$ R.H.) is regulated to measure.

SMD MHZ CERAMIC FILTER CF73 SERIES VA5 TYPE

RECOMMENDED REFLOW SOLDERING STANDARD CONDITION

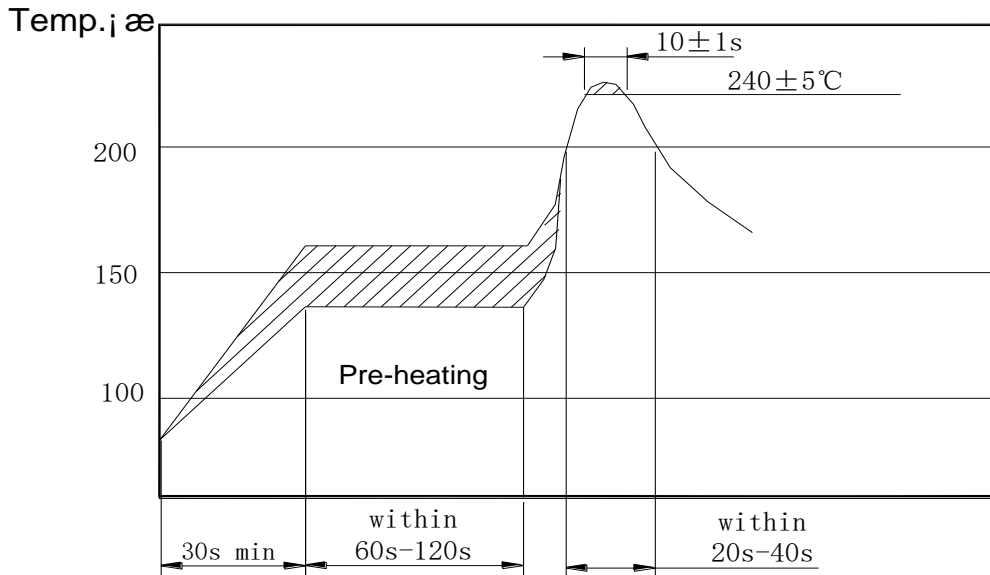

RECOMMENDED LAND PATTERN

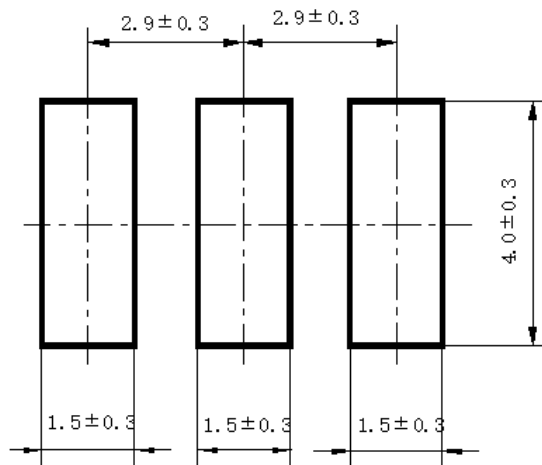

- (1): Input
- (2): Ground
- (3): Output

SMD MHZ CERAMIC FILTER CF73 SERIES VA5 TYPE

TPAE/REEL DIMENSIONS (mm)

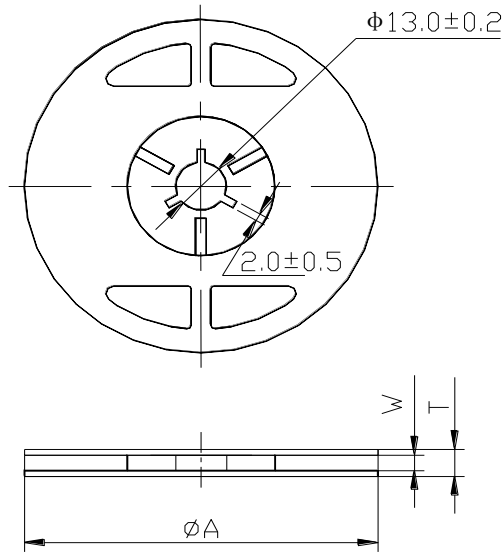

ϕA	W	T	Pieces per reel	Carrier tape size
330 ± 3	16.4min	22.4max	4000 typ.	16

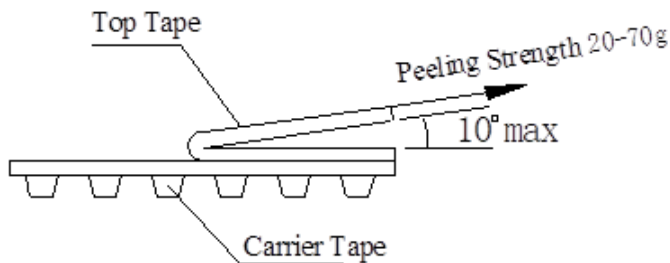
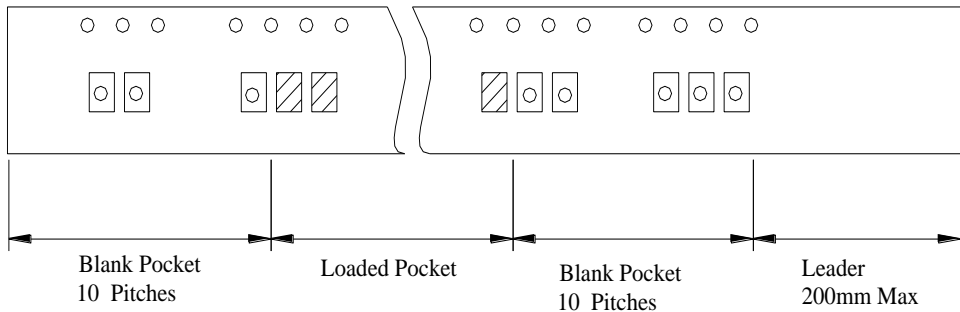

SMD MHZ CERAMIC FILTER CF73 SERIES VA5 TYPE

NOTES

- Don't apply excess mechanical stress to the component and terminals at soldering. Do not use this product with bend.
- Do not clean or wash the component for it is not hermetically sealed.
- Do not use strong acidity flux, more than 0.2wt% chlorine content, in flow soldering.
- Don't be close to fire.
- This specification mentions the quality of the component as a single unit. Please insure the component is thoroughly evaluated in your application circuit
- Expire date (Shelf life) of the products is 12 months after delivery under the conditions of a sealed and an unopened package. Please use the products within 12 months after delivery. If you store the products for a long time (more than 12 months), use carefully because the products may be degraded in the solder-ability or rusty. Please confirm solder-ability and characteristics for the products regularly.
- Exposure components under soldering condition that is exceeding our recommendation will increase the failure dangerous.
- Please contact us before using the product as automobile electronic component.
- Please return one of these specifications after your signature of acceptance.
- When something gets doubtful with this specifications, we shall jointly work to get an agreement.
- For questions on technology, prices and delivery, please contact our sales offices or e-mail:
sales@NextGenComponent.com .

DISCLAIMER

NextGen Components, Inc. reserves the right to make changes to the product(s) and or information contained herein without notice. No liability is assumed as a result of their use or application. No rights under any patent accompany the sale of any such product(s) or information

5/24/2023

10