

PROTECTION PRODUCTS

Description

μ Clamp[®] TVS diodes are designed to protect sensitive electronics from damage or latch-up due to ESD. They are designed to replace 01005 size multilayer varistors (MLVs) in portable applications such as cell phones, notebook computers, and other portable electronics. TVS diodes offer desirable characteristics for board level protection including fast response time, low operating and clamping voltage, and no device degradation.

μ Clamp[®]5011Z2C features extremely good ESD protection characteristics highlighted by low dynamic resistance, low peak ESD clamping voltage, and high ESD withstand voltage (+/-15kV contact per IEC 61000-4-2). Low maximum capacitance (5pF at VR=0V) minimizes loading on sensitive circuits. Each device will protect one data or power line operating at 5 Volts.

μ Clamp5011Z2C is in a 2-pin SLP0402P2X4C package measuring 0.43 x 0.23 mm with a nominal height of only 0.15mm. Leads are finished with NiAu. The small package gives the designer the flexibility to protect single lines in applications where arrays are not practical. The combination of small size and high ESD surge capability makes them ideal for use in portable applications such as cellular phones and wearables.

Package Dimension

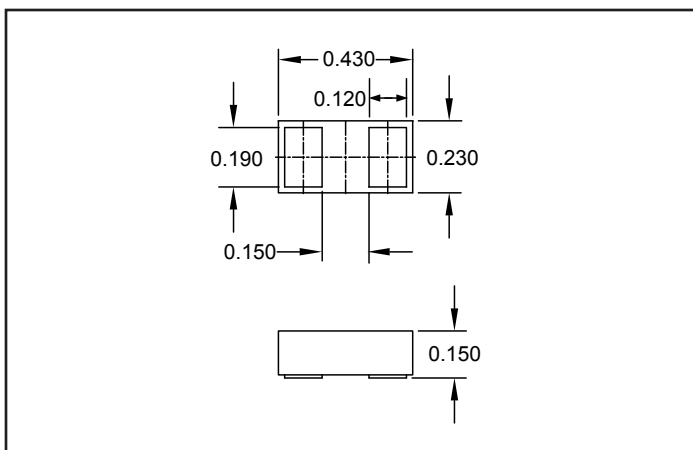

Features

- High ESD withstand voltage: +/-15kV (contact) and +/-15kV (air) per IEC 61000-4-2
- Ultra-small 01005 package
- Protects one line
- Low ESD clamping voltage
- Working voltage: 5V
- Capacitance: 5pF Maximum
- Low leakage current
- Low dynamic resistance: 0.15 Ohms (Typical)
- Solid-state silicon-avalanche technology

Mechanical Characteristics

- SLP0402P2X4C package
- Pb-Free, Halogen Free, RoHS/WEEE compliant
- Nominal Dimensions: 0.43 x 0.23 x 0.15 mm
- Lead Finish: NiAu
- Marking: Unmarked
- Packaging: Tape and Reel

Applications

- Smartphones & Accessories
- Smartwatch and other Wearables
- Portable Instrumentation
- Notebook Computers
- Tablets

Schematic & Pin Configuration

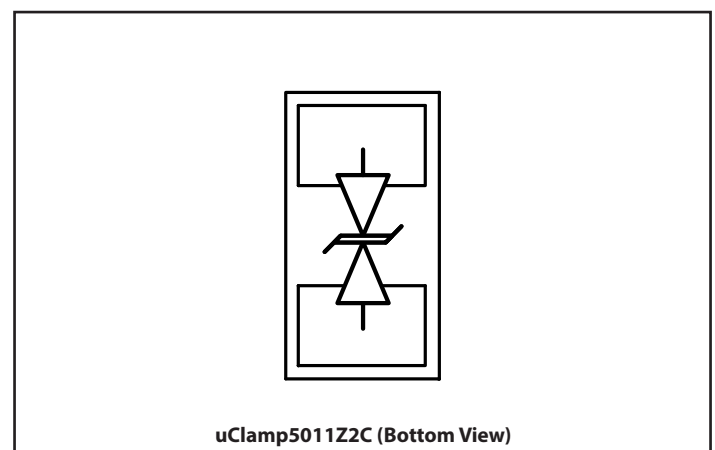

Absolute Maximum Rating

Rating	Symbol	Value	Units
Peak Pulse Power (tp = 8/20μs)	P _{PK}	30	W
Peak Pulse Current (tp = 8/20μs)	I _{PP}	2	A
ESD per IEC 61000-4-2 (Air) ⁽¹⁾ ESD per IEC 61000-4-2 (Contact) ⁽¹⁾	V _{ESD}	±15 ±15	kV
Operating Temperature	T _J	-40 to +125	°C
Storage Temperature	T _{STG}	-55 to +150	°C

Electrical Characteristics (T=25°C unless otherwise specified)

Parameter	Symbol	Conditions	Min.	Typ.	Max.	Units
Reverse Stand-Off Voltage	V _{RWM}	T = -40 to +125			5	V
Reverse Breakdown Voltage	V _{BR}	I _t = 1mA	6.5	8.5	10.5	V
Reverse Leakage Current	I _R	V _{RWM} = 5V		5	20	nA
Clamping Voltage	V _C	I _{PP} = 2A, tp = 8/20μs			12	V
ESD Clamping Voltage ²	V _C	I = 4A, tlp = 0.2/100ns		8		V
		I = 16A, tlp = 0.2/100ns		9.8		
Dynamic Resistance ^{2,3}	R _{DYN}	tlp = 0.2/100ns		0.15		Ω
Junction Capacitance	C _J	V _R = 0V, f = 1MHz		3.5	5	pF

Notes

- 1) Measured with a 20dB attenuator, 50 Ohm scope input impedance, 2GHz bandwidth. ESD gun return path connected to ESD ground plane.
- 2) Transmission Line Pulse Test (TLP) Settings: tp = 100ns, tr = 0.2ns, I_{TLP} and V_{TLP} averaging window: t1 = 70ns to t2 = 90ns.
- 3) Dynamic resistance calculated from I_{TLP} = 4A to I_{TLP} = 16A

Typical Characteristics

ESD Clamping (8kV Contact per IEC 61000-4-2)

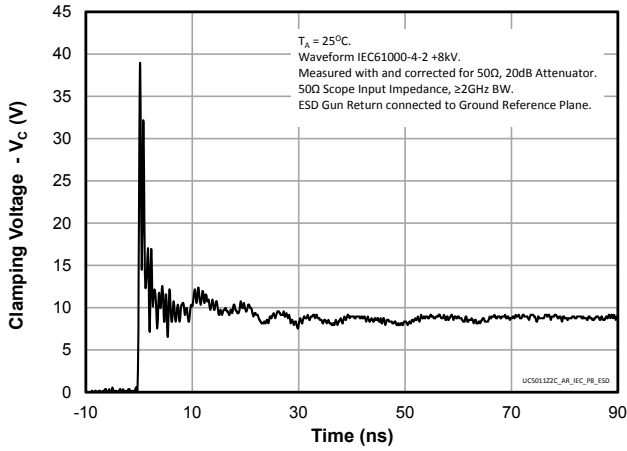

ESD Clamping (-8kV Contact per IEC 61000-4-2)

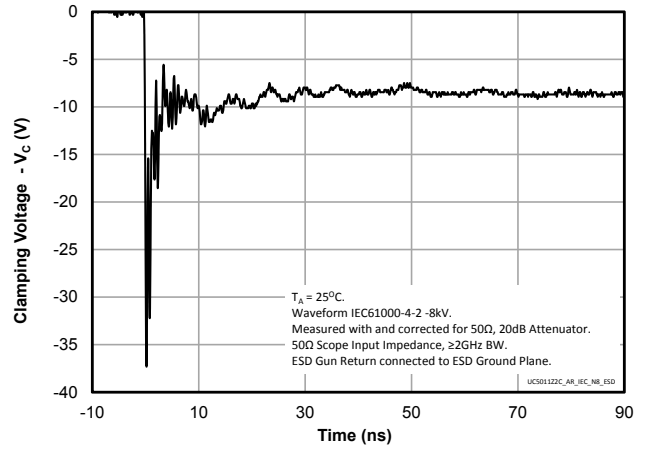

TLP Characteristic (Positive Pulse)

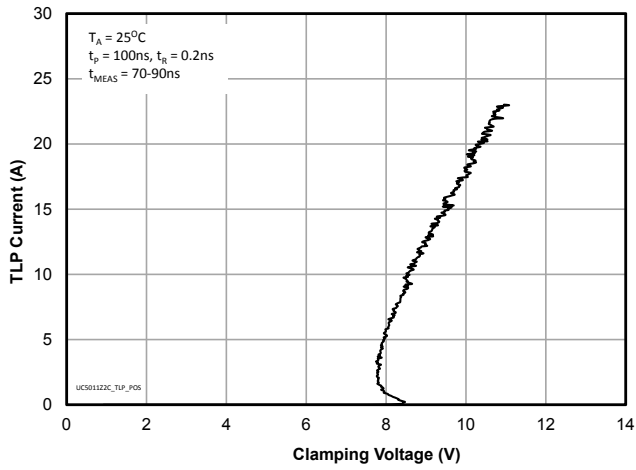

TLP Characteristic (Negative Pulse)

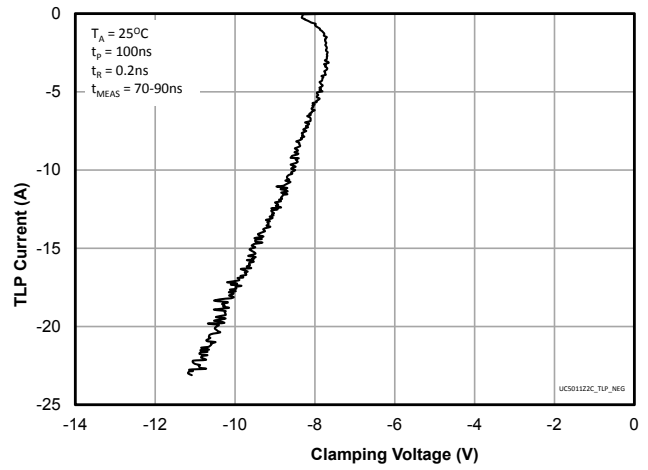

Clamping Voltage vs. Peak Pulse Current (tp=8/20us)

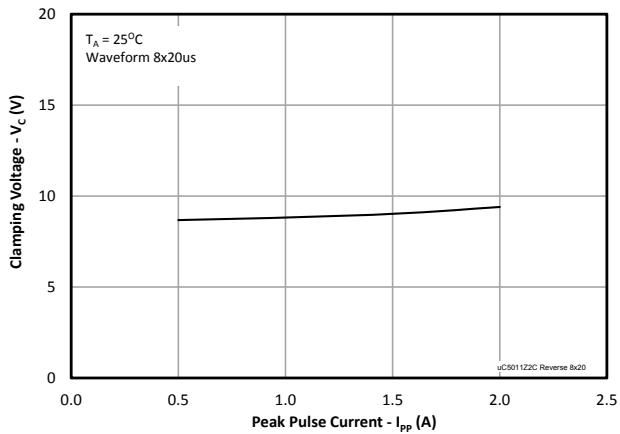

Capacitance vs. Reverse Voltage

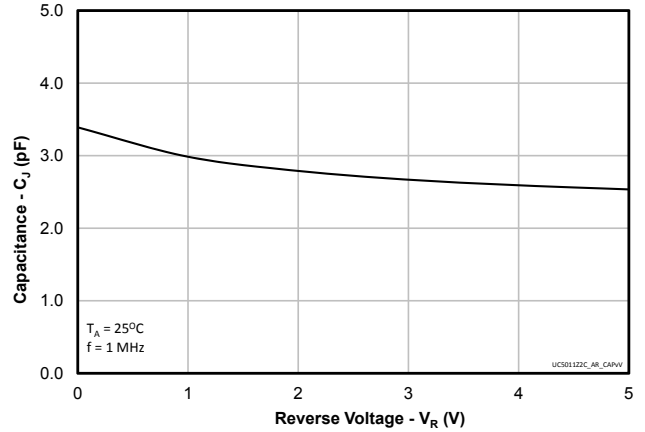

Application Information

Assembly Guidelines

The small size of this device means that some care must be taken during the mounting process to ensure reliable solder joints. Assembly guidelines are shown in Table 1. Note that these are only recommendations and should serve only as a starting point for design since there are many factors that affect the assembly process. Exact manufacturing parameters will require some experimentation to get the desired solder application.

Table 1 - Assembly Guidelines

Assembly Parameter	Recommendation
Solder Stencil Design	Laser Cut, Electro-Polished
Aperture Shape	Rectangular with Rounded Corners
Solder Stencil Thickness	0.075mm (0.003") or 0.050mm (0.002")
Solder Paste Type	Type 4 Size Sphere or Smaller
Solder Reflow Profile	Per JEDEC J-STD-020
PCB Solder Pad Design	Solder Mask Defined
PCB Pad Finish	OSP or NiAu

Solder Stencil

Stencil design is one of the key factors which determine the volume of solder paste which is deposited. For small pitch packages like the SLP0402P2X4C, Semtech recommends a stencil with square aperture and rounded corners for consistent solder release. The stencil should be laser cut with electro-polished finish. Stencil thickness of 0.075mm (0.003") or 0.050mm (0.002") may be used. A 0.100mm (0.004") stencil is not recommended as the resulting area ratio is too small to ensure proper solder coverage on the pad.

Based on board mount test results, Semtech's recommended mounting pattern for each size stencil are shown in Figure 1 and Figure 2. To achieve sufficient solder deposition volume using the 0.075mm thick stencil, the dimensions of the opening are the same as the recommended land pad dimensions. For the 0.050mm

thick stencil, the openings are slightly smaller than the land pad resulting in an area ratio of approximately 0.79. A larger opening could result in device tilting after reflow due to too much solder being deposited on the pads. Due to the small apertures, a solder paste with Type 4 or smaller particles are recommended.

Figure 1 - Mounting Pattern - 0.075mm Stencil

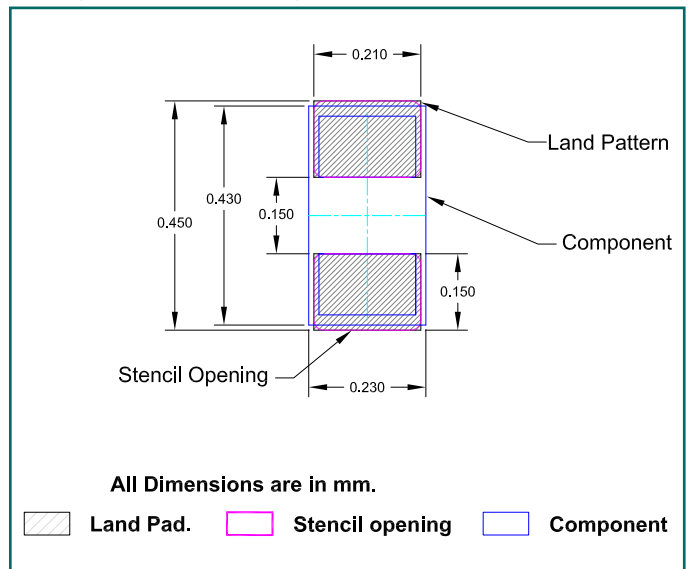
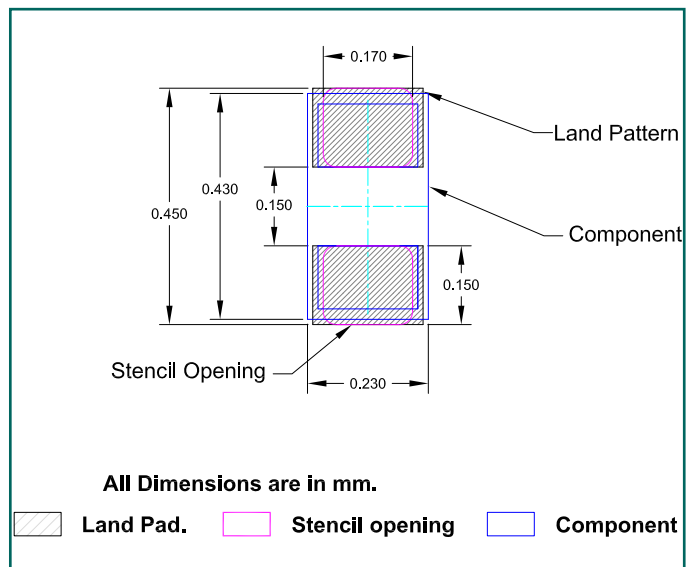
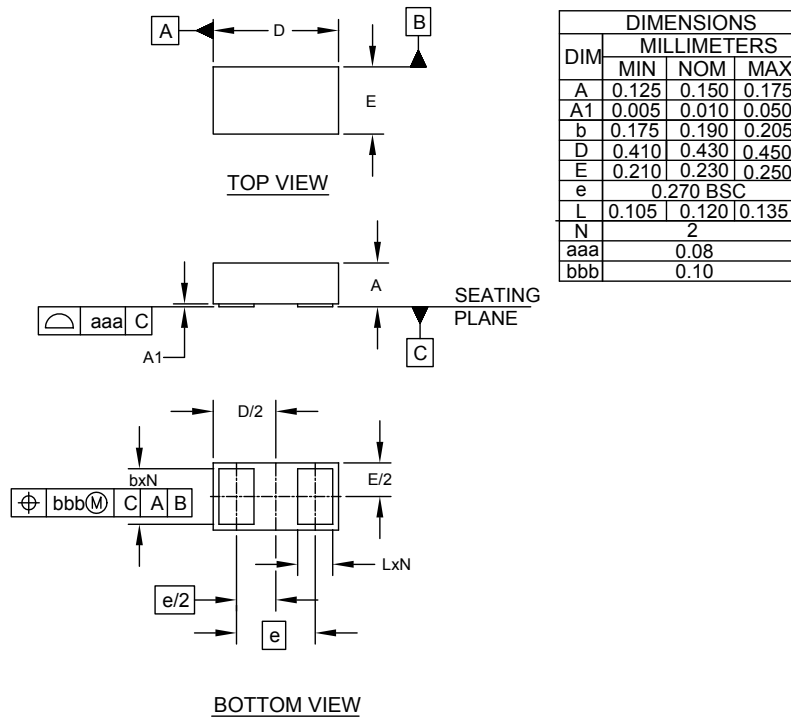

Figure 2 - Mounting Pattern - 0.050mm Stencil



Outline Drawing - SLP0402P2X4C



NOTES:

1. CONTROLLING DIMENSIONS ARE IN MILLIMETERS (ANGLES IN DEGREES).

Land Pattern - SLP0402P2X4C

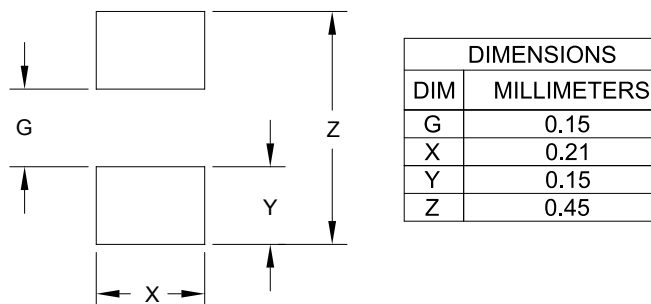

NOTES:

1. CONTROLLING DIMENSIONS ARE IN MILLIMETERS (ANGLES IN DEGREES).
2. THIS LAND PATTERN IS FOR REFERENCE PURPOSES ONLY.
CONSULT YOUR MANUFACTURING GROUP TO ENSURE YOUR COMPANY'S MANUFACTURING GUIDELINES ARE MET.

Marking Code

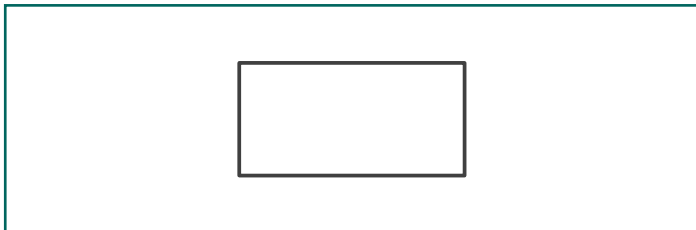

Note: Device is unmarked

Tape and Reel Specification

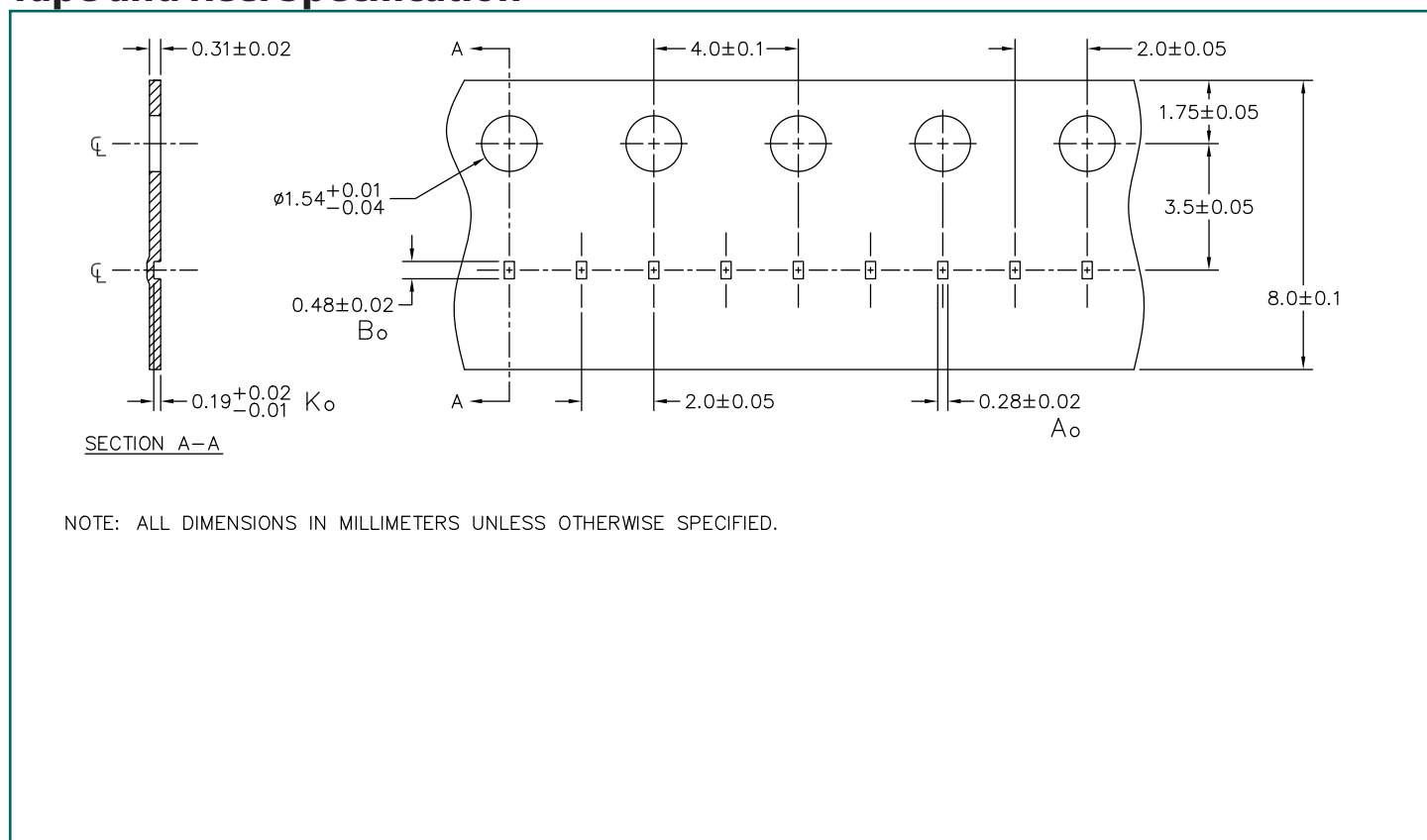

Ordering Information

Part Number	Qty per Reel	Pocket Pitch	Reel Size
uClamp5011Z2CTKT	20,000	2mm	7"
MicroClamp, uClamp and μ Clamp are registered trademarks of Semtech Corporation.			



IMPORTANT NOTICE

Information relating to this product and the application or design described herein is believed to be reliable, however such information is provided as a guide only and Semtech assumes no liability for any errors in this document, or for the application or design described herein. Semtech reserves the right to make changes to the product or this document at any time without notice. Buyers should obtain the latest relevant information before placing orders and should verify that such information is current and complete. Semtech warrants performance of its products to the specifications applicable at the time of sale, and all sales are made in accordance with Semtech's standard terms and conditions of sale.

SEMTECH PRODUCTS ARE NOT DESIGNED, INTENDED, AUTHORIZED OR WARRANTED TO BE SUITABLE FOR USE IN LIFE-SUPPORT APPLICATIONS, DEVICES OR SYSTEMS, OR IN NUCLEAR APPLICATIONS IN WHICH THE FAILURE COULD BE REASONABLY EXPECTED TO RESULT IN PERSONAL INJURY, LOSS OF LIFE OR SEVERE PROPERTY OR ENVIRONMENTAL DAMAGE. INCLUSION OF SEMTECH PRODUCTS IN SUCH APPLICATIONS IS UNDERSTOOD TO BE UNDERTAKEN SOLELY AT THE CUSTOMER'S OWN RISK. Should a customer purchase or use Semtech products for any such unauthorized application, the customer shall indemnify and hold Semtech and its officers, employees, subsidiaries, affiliates, and distributors harmless against all claims, costs damages and attorney fees which could arise.

The Semtech name and logo are registered trademarks of the Semtech Corporation. All other trademarks and trade names mentioned may be marks and names of Semtech or their respective companies. Semtech reserves the right to make changes to, or discontinue any products described in this document without further notice. Semtech makes no warranty, representation or guarantee, express or implied, regarding the suitability of its products for any particular purpose. All rights reserved.

© Semtech 2015

Contact Information

Semtech Corporation
200 Flynn Road, Camarillo, CA 93012
Phone: (805) 498-2111, Fax: (805) 498-3804
www.semtech.com