

11000 Ambient Air Monitor

1.2 LPM



The 11000 is a low cost, high-accuracy dust monitor designed for outdoor particulate and gas monitoring. These robust monitors provide reliable, accurate measurement of airborne contamination allowing for the detection of environmental and public health concerns. The first real time monitor to provide 30 accurate particulate size channels at higher concentrations.

Real-Time Data

30 particle size channels recorded by the 11000 Monitor are stored in an internal 65,000 record non-volatile memory at user-defined data sampling rates (1 second to 99 hours). The high time-resolution of the Model 11000 measurements provides a near-instantaneous look at changing airborne particulate concentrations, leading to a well-defined model of local point source influences that may disproportionately affect air quality.

Highest Concentration OPC based Monitor

The 11000 series has the highest concentration available in the market for an optical particle counter based ambient air monitor. With a flow rate of 1.2 LPM the sensor is capable of accurately counting and sizing particles up to 27,000,000 particles/ft³ (1,000 particles/cm³). The monitor can handle TPM concentrations up to 20,000 µg/m³ before experiencing coincidence loss.

Applications

- Airborne Pollution and Environmental Research
- Perimeter or Fence-line Monitoring for Construction, Remediation or Waste Sites
- Mine and Quarry Fence-line Monitoring for dust control operations
- City Wide or Community Air Pollution Monitoring
- Roadside Emissions Monitoring
- Medical Facilities Property Monitoring
- Power Line Wildfire Monitoring
- Environmental Disasters
- Monitor for 24 hours a day, 7 days a week, 365 days a year

Features and Benefits

- Concurrent measurement of multiple, user selectable PM sizes from 0.3 µm to 10 µm including TPM of particles up to 25.0 µm
- Closed-loop humidity control for incoming air stream (to provide more accurate particulate sizing)
- Closed-loop condensation control within the enclosure
- Aerosol Concentration Range of 0.01 to 20,000 µg/m³
- ULTRAGUARD® Fiberglass reinforced polyester NEMA 4 rated outdoor tamper-proof enclosure with internal thermal control
- Optional pole or tripod mount options
- Density correction by channel for 30 channels allowing for highly accurate approximations of mass concentrations

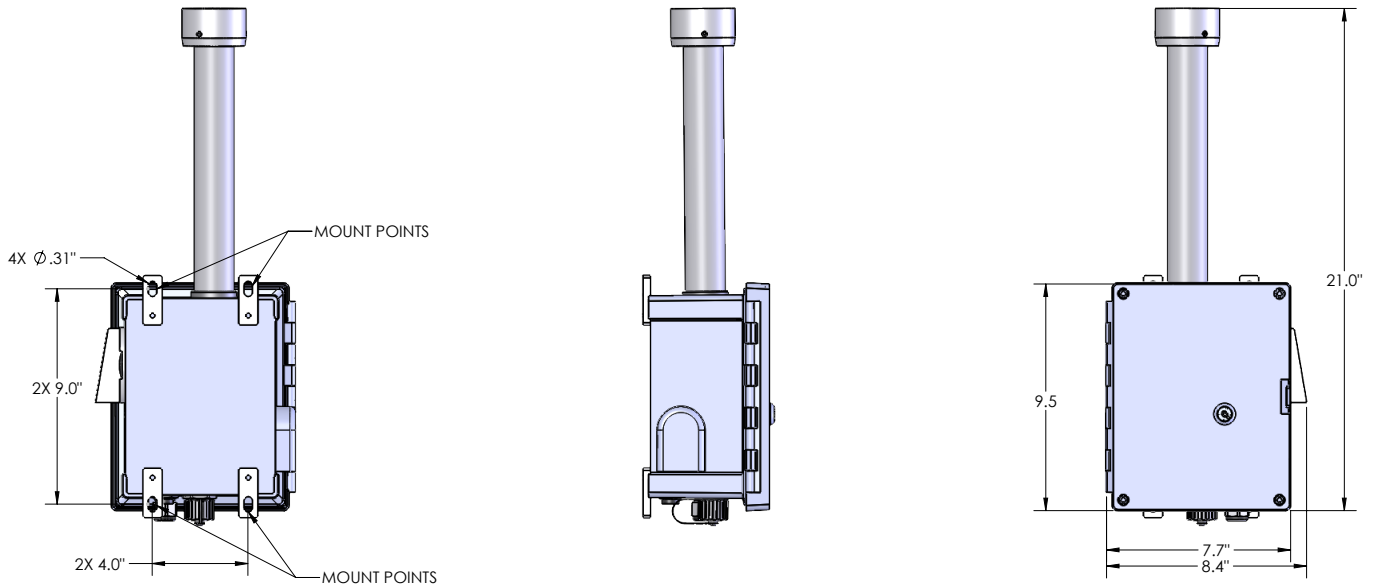

Specifications

Model	11000
Size Range	0.3 to 25 μm
Size Channels	Factory calibrated at 0.3, 0.5, 1.0, 2.5, 5.0, 10.0 μm
Flow rates / Accuracy	1.2 LPM $\pm 3\%$
Aerosol Concentration Range	0.01 to 20,000 $\mu\text{g}/\text{m}^3$
Light Source	Long life laser diode
Resolution	0.00003 $\mu\text{g}/\text{m}^3$
Zero Stability	No appreciable drift
Count Modes	Cumulative/differential count/ m^3 , count/ ft^3 , and mass concentration (PM)
Log Interval	Minimum 1 second with no hold time, maximum 99 hours
Calibration	NIST traceable
Vacuum Source	Internal pump with automatic flow control
Number of Channels	Up to 30 channels
Communication Modes	ModBus over RS485 or USB direct (USB to IMS-9K software utility)
Optional Communication Modes	Future Plug & Play (optional) Communication Modules - Wi-Fi, LoRaWAN and Ethernet
Environmental Sensor	Temperature $\pm 2^\circ\text{C}$, Relative Humidity $\pm 9\%$, and Barometric Pressure $\pm 2.5\text{mbar}$
Alarm	Alarms for all particle values, environmental sensors, flow and sensor failure
Calibration	Particle sensor recommended once per year
User Calibration	Field Calibration of Temperature and Humidity possible with included utility software
External Surface	ULTRAGUARD [®] Fiberglass reinforced polyester - compression molded SMC box and Cover
Enclosure	Temperature controlled ventilation blower and heated backplate for environmental extremes
Dimensions (L x W x H)	12.85" x 7.41" x 25.54" (32.7 cm x 18.9 cm x 64.9 cm) includes barb fittings
Weight	12.5 lbs. (5.66 kg)
Accessories	Quick start guide, operating manual on USB flash drive, mounting feet
Optional Accessories	Printed manual, data cable, pole mounting hardware kit
Data Storage	Internal 65,000 sample records (rotating buffer) including particle count data and environmental data
Sample Time	1 second to 99 hours
Power	110 to 240 VAC 50/60 Hz universal in-line power supply
Operating Conditions	-4° to 122°F (-20° to 50°C) / 20% to 95% non-condensing
Warranty	2 year limited warranty. Extended warranties available

PAT. <https://particlepatents.com/> Additional Patents Pending.
 Particles Plus, Inc. reserves the right to change specifications without notice.
 Contact hello@particlesplus.com or your local distributor for more details.
 Particles Plus and the Particles Plus logo are trademarks of Particles Plus, Inc.
 ©2022 Particles Plus, Inc. All rights reserved.

REV 20230210-11000



31 Tosca Drive
 Stoughton, MA 02072 U.S.A.
 +1-781-341-6898
www.particlesplus.com