

Instruction Manual for Evaluation Board of TB67H452FTG

July 10, 2019

Rev.1.1

【Outline】

The TB67H452FTG is a two-phase bipolar driver using a PWM chopper for dual stepping motors with the clock control system. Adopted 130 nm analog process achieves the rating of 40 V and 2.0 A.

The IC has four H-bridge circuits and an operation mode switching circuit. By switching the operation mode, it can control up to four brushed DC motors as well as two stepping motors.

This evaluation board mounts necessary components to evaluate the IC. Any special preparation is not needed. Please sense high controllability of stepping motors and brushed DC motors by using the TB67H452FTG.

【Note】

In using, please be careful about the thermal condition sufficiently.

As for each control signal, please refer to the IC specification by accessing to the below URL.

<http://toshiba.semicon-storage.com/us/product/linear/motordriver/detail.TB67H452FTG.html>

Further, the application of this evaluation board is limited to the purpose of evaluating and learning the motor control. Please do not ship them to a market.

Basic Notes in Using Evaluation Board



Power supply voltage and operating voltage range

Apply the voltage to the VM pin in evaluating the IC.

In case of using the level select pin mounted on this evaluation board, the voltage should be applied to the VDD pin.

Though the absolute maximum rating of the VM power supply voltage is +40 V, evaluate the IC within the rated operating range of +6.3 V to 38.0 V.

The VDD voltage should be within the logic input voltage range of +3.3 V to 5.0 V in using the level select pin.

Power on and off sequence

There are no special procedures in applying a power supply and shutdown since the IC implements the under voltage detection circuit (UVLO).

However, it is recommended to turn off the motor operation during the power on and the shutdown where the VM voltage is unstable. Start the motor operation by switching the input signals after the power supply voltage becomes stable.

Output current

Motor current should be 2.0 A or less that corresponds to the operating range.

However, the maximum current of the actual usage is limited depending on the usage conditions (the ambient temperature, the radiation path, the exciting design, etc.). Configure the most appropriate current value after calculating the heat and evaluating the board under the operating environment.

Control input

It is recommended to configure the input signals of ENABLE_AB, ENABLE_CD, AB_MODE1, AB_MODE2, CD_MODE1, CD_MODE2, CLK_AB and CLK_CD to low level while the VM voltage is not supplied.

When the logic signal is input without the VM voltage supply, the electromotive force is not generated.

Notes in Using Evaluation Board –Error detection circuits

Thermal shutdown circuit (TSD)

When the IC detects an over temperature (150°C (typ.)), the internal circuit turns off the output MOSFETs. Reassert the VM power supply or use the standby mode to release this function. The TSD is triggered when the IC is over heated irregularly. Make sure not to use the TSD function aggressively.

Over current protection (ISD)

When the current of the output transistors exceeds 4.0 A (typ.), the internal circuit turns off the output MOSFETs. The VM power supply is shut down and outputs are turned off till the VM power supply is applied again. Reassert the VM power supply or use the standby mode to release this function. The ISD is triggered when the outputs are in over current state irregularly. Make sure not to use the ISD function aggressively.

Under voltage detection circuit (UVLO)

When the VM pin voltage falls to 5.7 V (typ.), the internal circuit turns off the output MOSFETs. Internal circuits are reset when the UVLO is enabled. It is released when the VM pin voltage reaches 5.7 V (typ.).

* Value in operation and release of each protection circuit is for your reference and is not guaranteed.

Setting Evaluation Board 1

Setting motor control mode

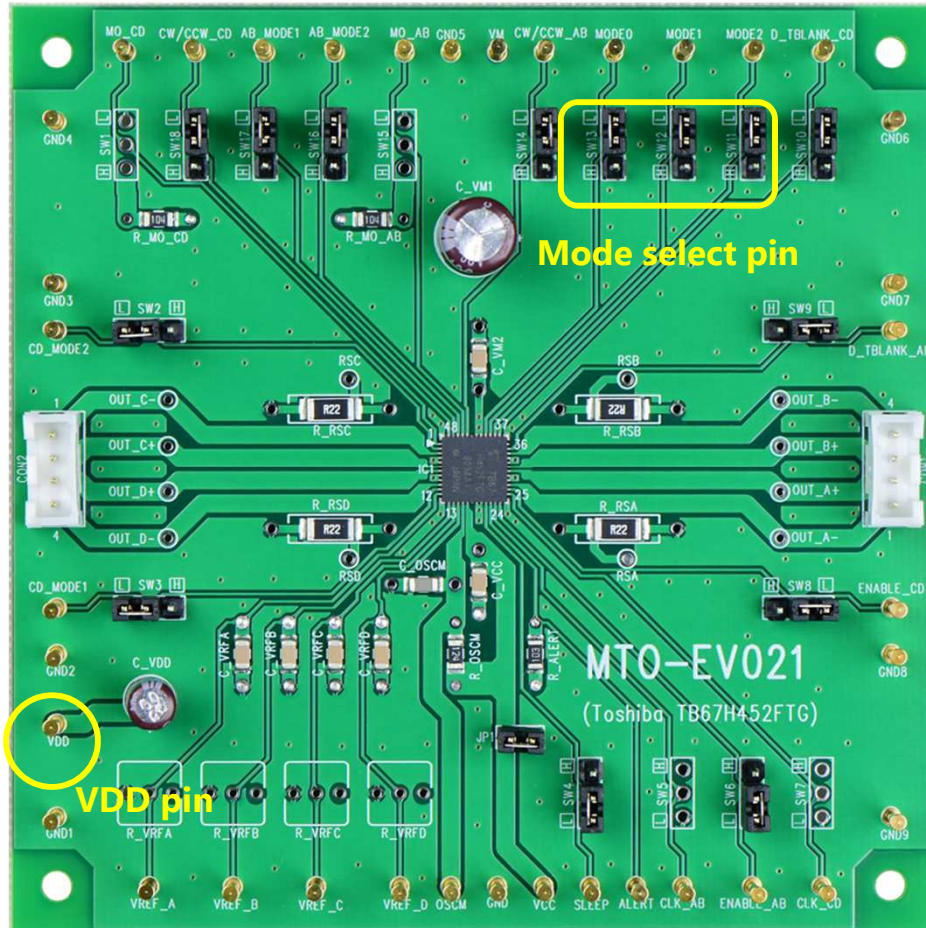

This evaluation board has a level select pin for setting the operation of the TB67H452FTG (shown in the photo below).

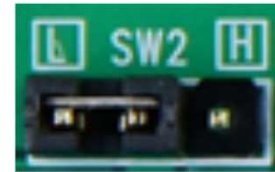

*It is set to the low level.

When selecting the function by using the level select pin, input high level from the VDD pin.

Motor control mode is set by using MODE0, MODE 1, and MODE2 pins.

MODE0	MODE1	MODE2	Motor control mode
H	H	H	Stepping Motor (S) ×2
L	H	H	DC Motor (L) (Combination)×2
H	L	H	Stepping Motor (L) (Combination)×1
L	L	H	DC Motor (S) ×4
H	H	L	DC Motor (L) (Combination)×1 + Stepping Motor (S)
L	H	L	DC Motor (S) ×2 + Stepper Motor (S)
H	L	L	Inhibited
L	L	L	Standby Mode

Setting Evaluation Board 2

Setting motor current

Setting motor current

$$I_{out(max)} = V_{REF(gain)} \times \frac{V_{ref(V)}}{R_{RS}(\Omega)}$$

$$V_{REF(gain)} = 1/5.0 \text{ (typ.)}$$

$$R_{RS} = 0.22 \Omega$$

By implementing potentiometers to R_VRFA, R_VRFB, R_VRFC, and R_VRFD, the VCC voltage of the internal regulator or the externally supplied VDD voltage can be divided, and generating the Vref voltage is possible.

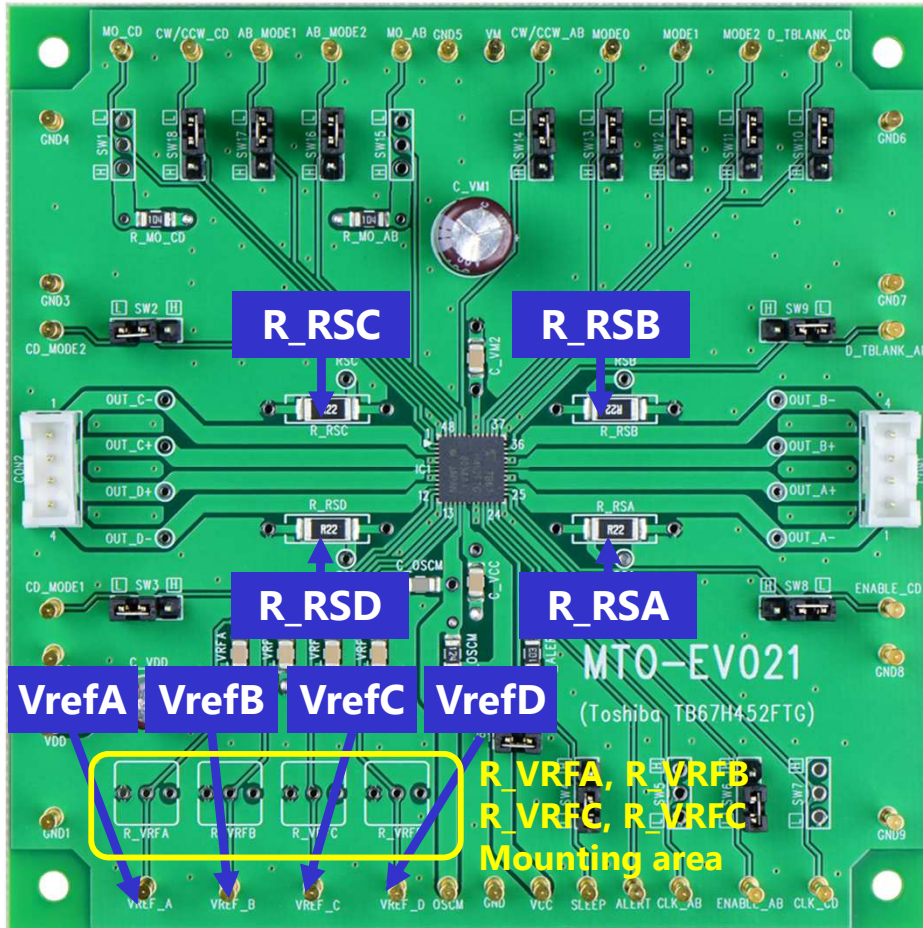

Waveforms of motor current

Value of setting motor current

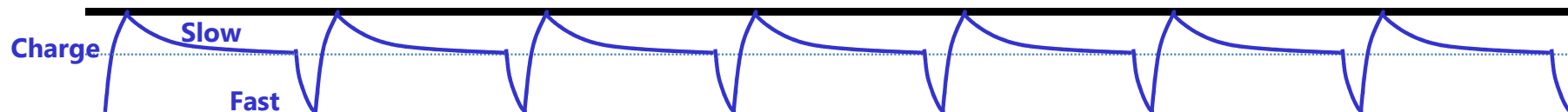

Setting Evaluation Board 3

Setting chopping frequency of motor constant current

Set the chopping frequency by referring to the table shown below. The resistor of 120 k Ω is adopted to R_OSCM and the capacitor of 270 pF is adopted to C_OSCM in order to provide the frequency of 100 kHz at the time of shipment.

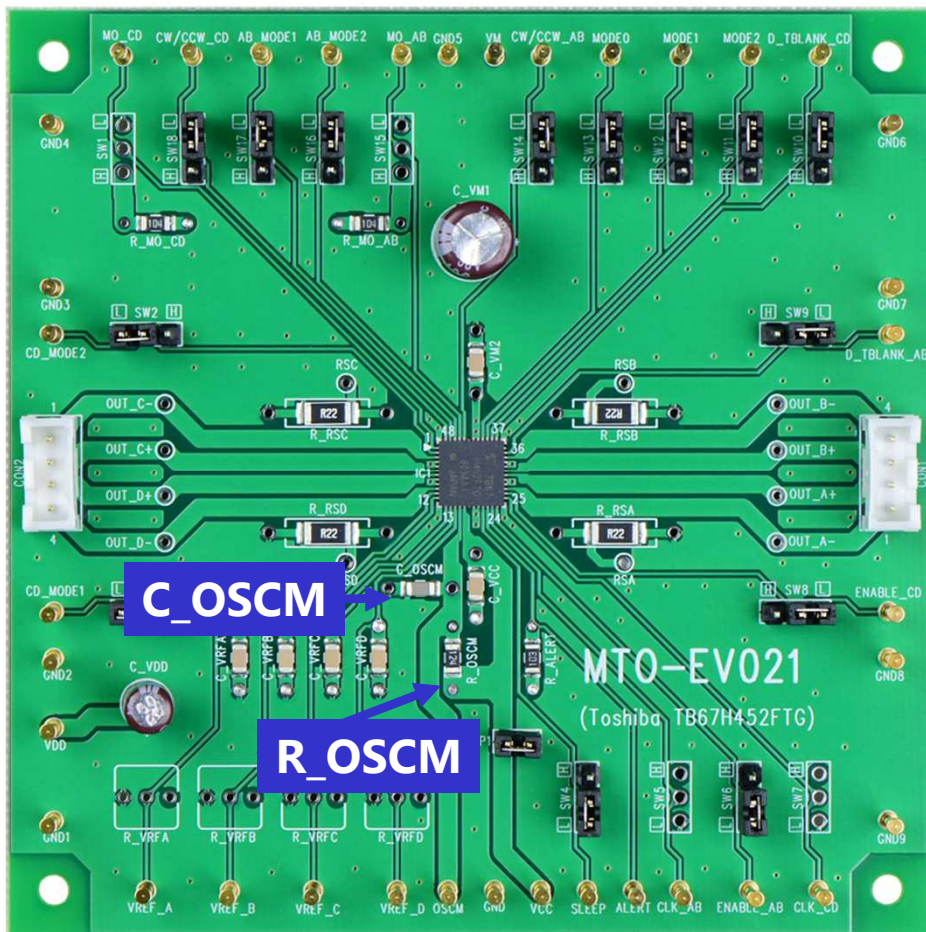

Chopping frequency [kHz]	C_OSCM[pF]	R_OSCM[k Ω]
150	150	180
140	180	100
130	180	150
120	220	100
110	180	220
100	270	120
90	330	68
80	330	130
70	390	130
60	470	120
50	560	180
40	820	68

Waveforms of motor current

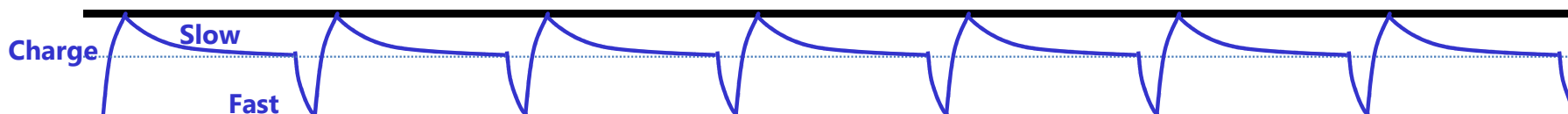

Value of setting motor current

Evaluation Board Connection Method 1

MODE0	MODE1	MODE2	Motor control mode
H	H	H	Stepping Motor (S) ×2

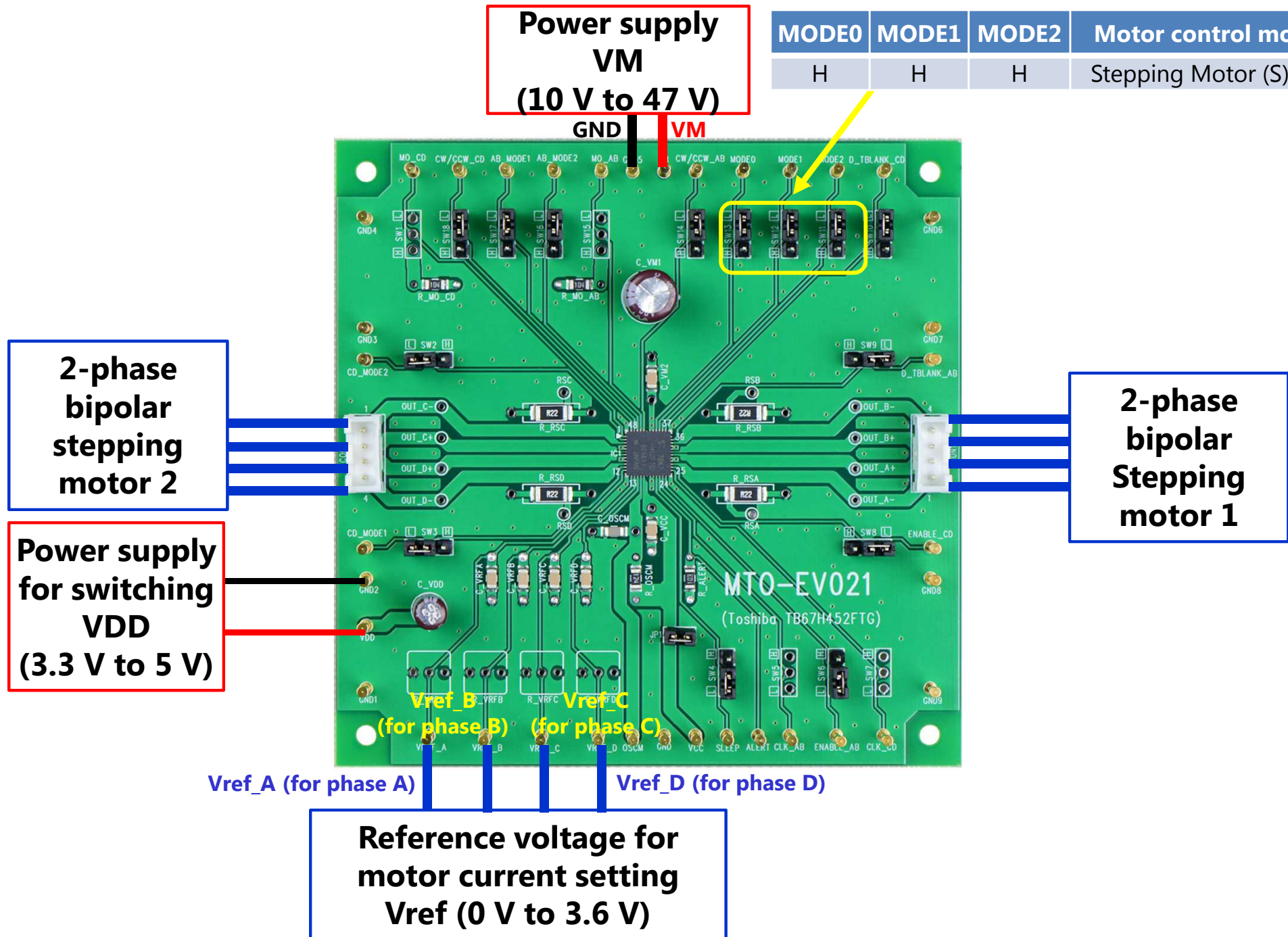

Evaluation Board Connection Method 2

Power supply
VM
(10 V to 47 V)

MODE0	MODE1	MODE2	Motor control mode
L	L	H	DC Motor (S) ×4

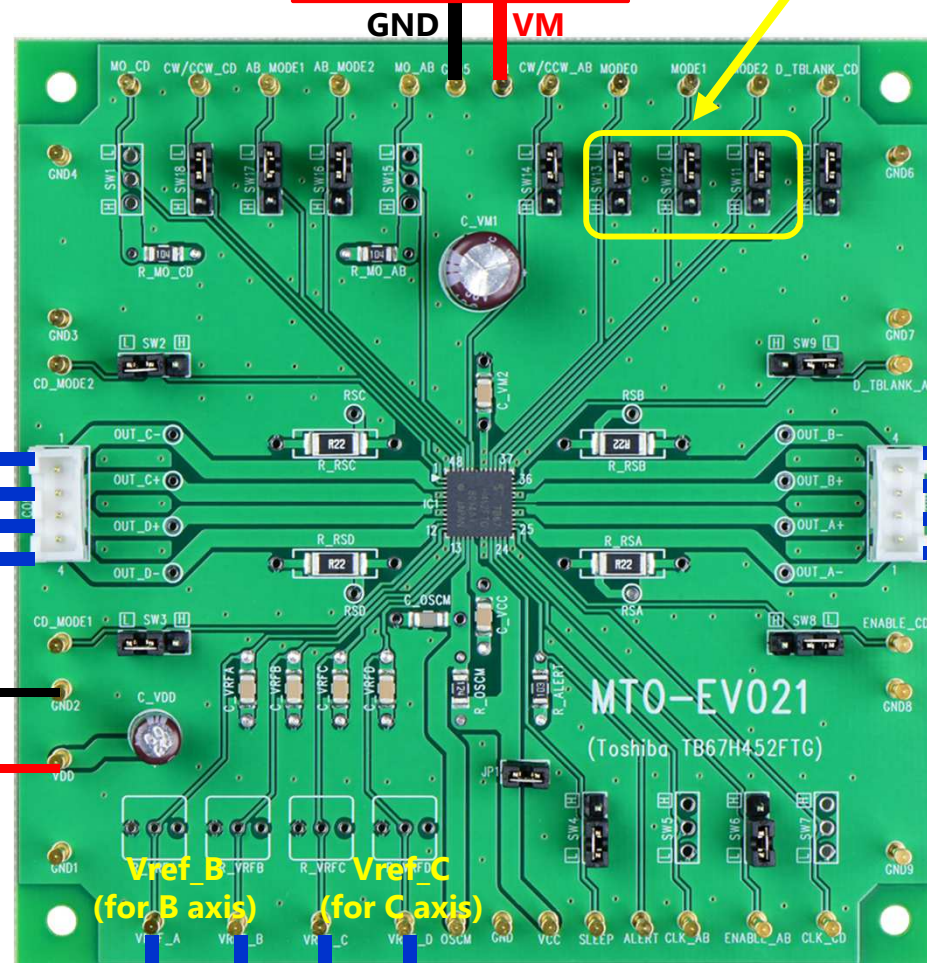

Brushed DC motor C

Brushed DC motor D

Brushed DC motor B

Brushed DC motor A

Power supply for switching VDD (3.3 V to 5 V)

Vref_A (for A axis) Vref_D (for D axis)

Reference voltage for motor current setting Vref (0 V to 3.6 V)

Circuit Diagram of Evaluation Board

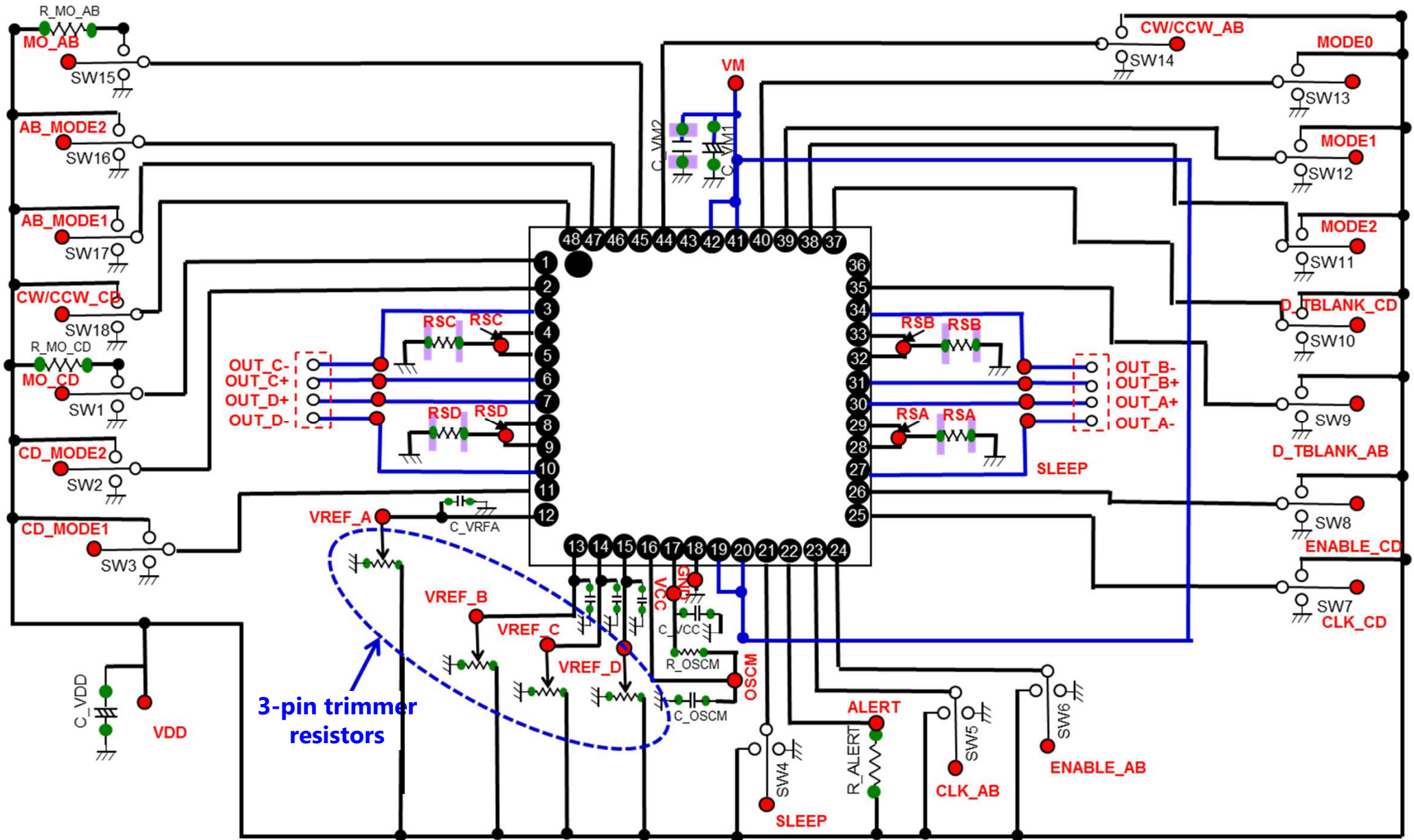

◆ Important Note ◆

● This product was not designed for use with devices which could cause personal injury in the event of failure or malfunction, including devices for use in areas including medical, military, aviation, aerospace, nuclear control, other types of safety mechanisms, etc., or for use in devices which require a high standard of safety. Do not use this product for such applications. This company assumes no liability for damages which may result from use of the product.

Manufactured and Distributed by



<https://www.marutsu.com>

Marutsuelec Co., Ltd.

5-2-2, Seiki Daiichi Building 7F, Sotokanda, Chiyoda-ku,
Tokyo 101-0021, Japan

Tel: +81-3-6803-0209 FAX: +81-3-6803-0213