



Product Specification

Ningbo East Electronics Limited
NO. 88 East Jinhui Road, Yinzhou Ningbo 315100, P.R.China
<http://www.east-mingtao.com>

Product Name:	External -Driven Piezo Transducer
Part Number:	TFM-15
Version:	1.02
Date:	2019-9-6
Note:	

East is an ISO 9001 , IATF16949 and ISO 14001 Certified Company

Revision History

Rev.	Description	Author/Date	Checked By	Approver
1.02	Quality management system revised	汤礼东 2019-9-6	吕文斌	王建成
1.01	Quality Certificate Symbol revised	刘宁 2015-2-12	汤礼东	王建成
1.0	Released	沈龙 2011-6-25	汤礼东	王建成

1. Part Number TFM-15

2. Dimension Drawing (Unit: mm)

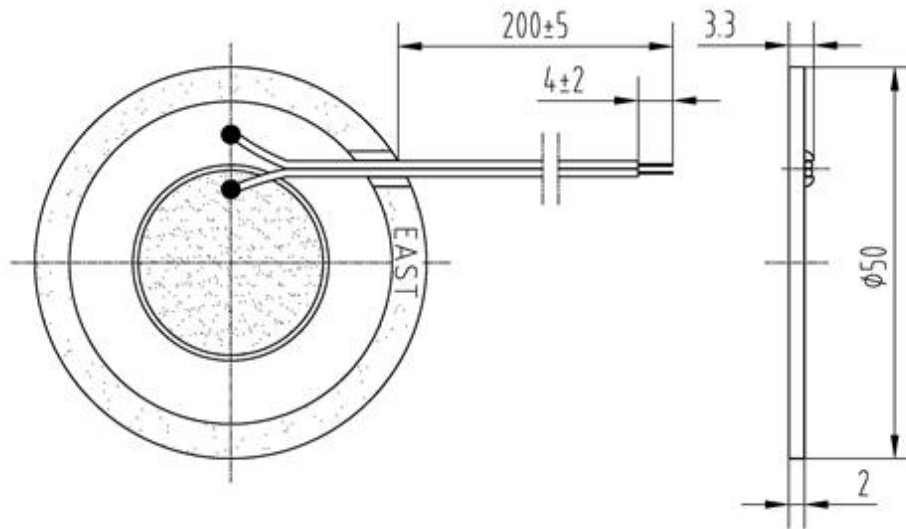

3. Specification

No.	Item	Specification
3-1	Min. Sound Pressure Level	75dB/1.0kHz/12Vp-p square wave /10cm
3-2	Allowed Input Voltage	40Vp-p
3-3	Capacitance	66±30% nF (At 120Hz)
3-4	Max. Consumption	6mA/1.0kHz/12Vp-p square wave
3-5	Resonant Frequency	1.0± 0.5kHz
3-6	Operating Temperature	-20~+70°C
3-7	Case Material /Color	ABS/Black
3-8	Weight	4.6g
3-9	Wire Standard	UL1095-28AWG

NOTES:

Test should be made under the conditions of room temperature ($20 \pm 10^\circ\text{C}$), normal humidity ($60 \pm 20\%$) and normal atmospheric pressure. In this case, however, that the judgment is questionable, the test conditions are to be changed to room temperature $20 \pm 2^\circ\text{C}$, relative humidity 60~70% and normal atmospheric pressure

4. Typical Frequency Response Curve

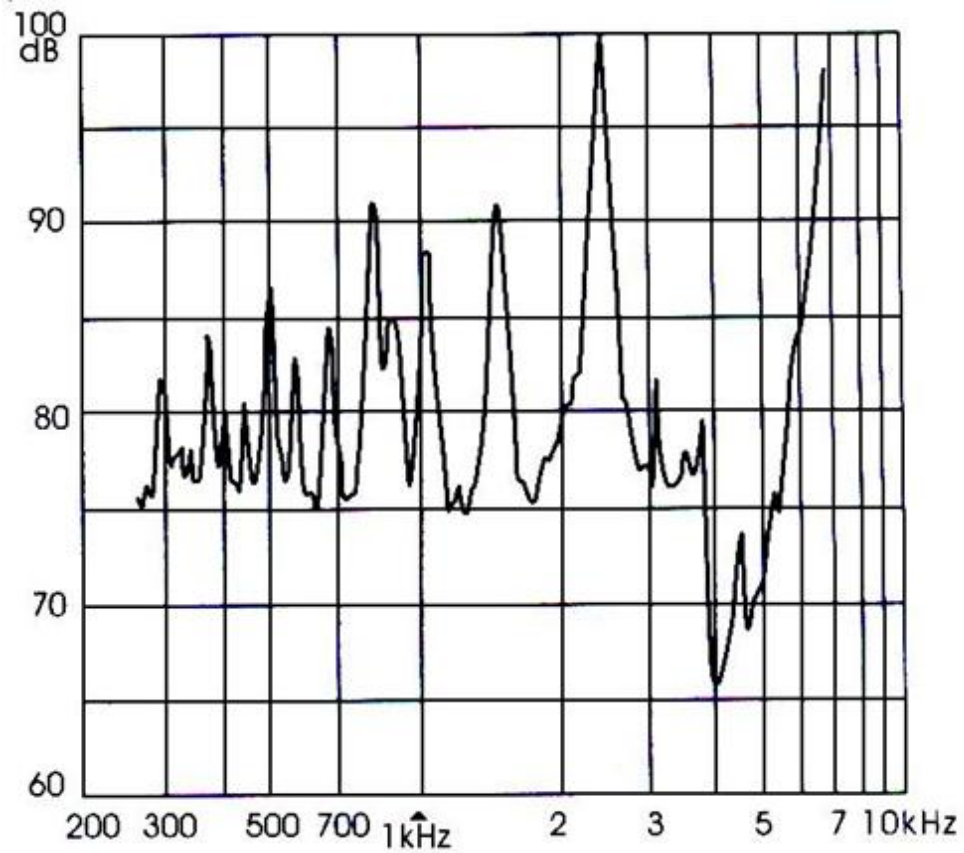

Note: Input Voltage 12Vp-p square wave
Distance 10 cm

5. Reliability Test

No.	Item	Method of Test	Tolerance after Testing
5-1	Operating Temperature	-20~+70°C	Sound pressure level initial value $\pm 10\text{dB}$ Max. consumption value $\pm 20\%$ Capacitance value $\pm 20\%$
5-2	Storage in high temperature	Storage in +70°C test box 96 hours then exposed to the room temperature for 2 hours	
5-3	Storage in low temperature	Storage in -20°C test box 96 hours then exposed to the room temperature for 2 hours	
5-4	Life test in the room temperature	Operate the product continuously 5 seconds on 5 seconds off 300 hours at rated voltage	
5-5	Temperature / humidity cycle test	Storage in +40°C, 93 \pm 3%RH test box 96 hours then exposed to the room temperature for 2 hours	
5-6	Temperature (high and low) cycle test	Conduct the test for 5 cycles without applying power then expose to the room temperature for 2 hours.(See Figure 5-6)	
5-7	Vibration test	Conduct the test for the directions of X Y and Z for 0.5 hour each (total 1.5 hours). To-and Fri sweep time(from 10 to 55Hz and then 55 to 10) under single amplitude of 0.75mm is 3 minute, then expose to the room temperature for 2 hours	
5-8	Drop test	Drop a product naturally from the height of 700mm onto the surface of 100mm thick wooden board. Two directions: upper and side of the product are to be applied for this drop test once respectively	

Figure 5-6

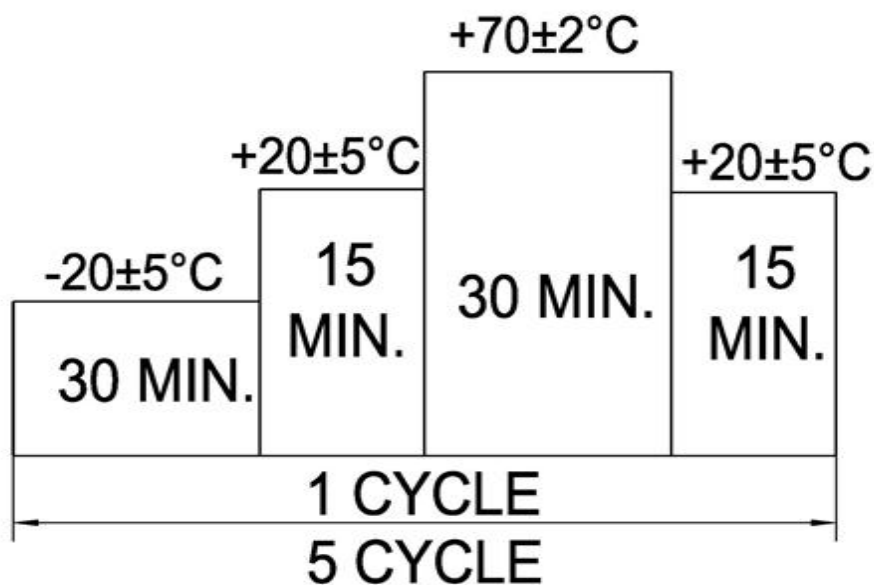

6. Electrical Testing Method

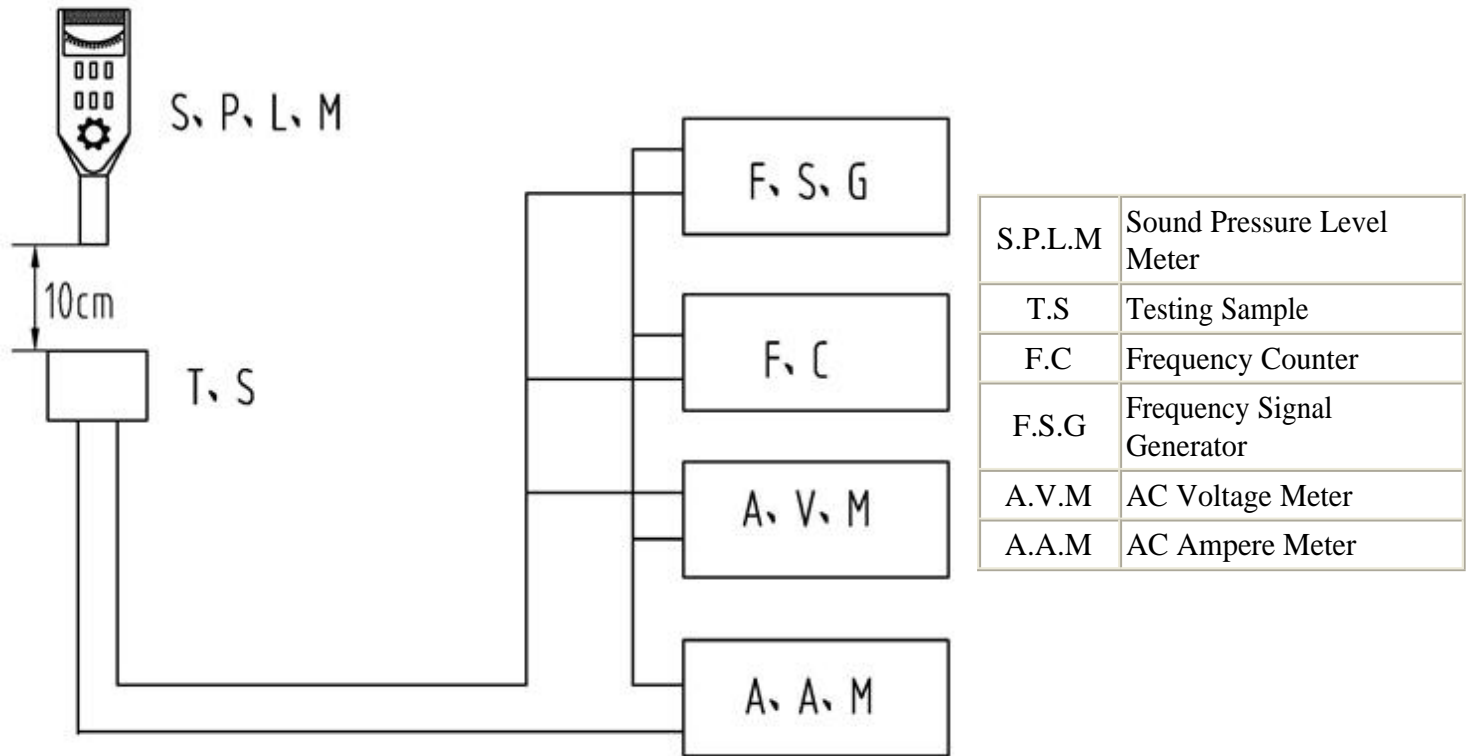

7. Packing Information

Packing: 2160 pcs per export carton

Carton Size: 47× 30.5× 19 cm

G. Weight: 12.8kgs **N. Weight:** 10 kgs