

## 600mA, High Efficiency uPOL Module

## MUN3C1BR6-MB/ MUN3C1HR6-MB

### FEATURES:

- High Density Power Module
- 600mA Output Current
- Input Voltage Range from 2.7V to 5.5V
- Fixed Output Voltage
- 100% Maximum Duty Cycle with Low Dropout
- Enable Function
- Automatic Power Saving/PWM Mode
- Protections (UVLO, OCP: Non-latching)
- Internal Soft Start
- Compact Size: 2.5mm\*2.0mm\*1.1mm
- Pb-free for RoHS compliant
- MSL 2, 260C Reflow

### APPLICATIONS:

- Single Li-Ion Battery-Powered Equipment
- LDOs Replacement
- Cell phone / PDAs / Palmtops

### GENERAL DESCRIPTION:

The MUN3C1XR6-MB power module series is non-isolated dc-dc converters that can deliver up to 600mA of output current. The PWM switching regulator, high frequency power inductor are integrated in one hybrid package. It needs input and output capacitor only and no additional feedback circuit.

The MUN3C1XR6-MB power module series has automatic operation with PWM mode and power saving mode according to loading. Other features include remote enable function, internal soft-start, non-latching over current protection, and input under voltage locked-out capability.

The low profile and compact size package (2.5mm × 2.0mm × 1.1mm) is suitable for automated assembly by standard surface mount equipment. The MUN3C1XR6-MB power module series is Pb-free and RoHS compliance.

### TYPICAL APPLICATION CIRCUIT & PACKAGE:

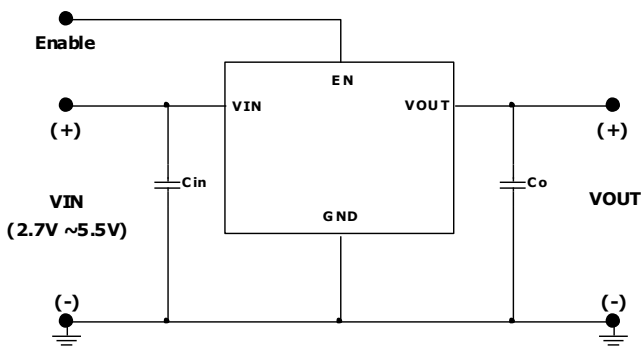

FIGURE 1 TYPICAL APPLICATION CIRCUIT

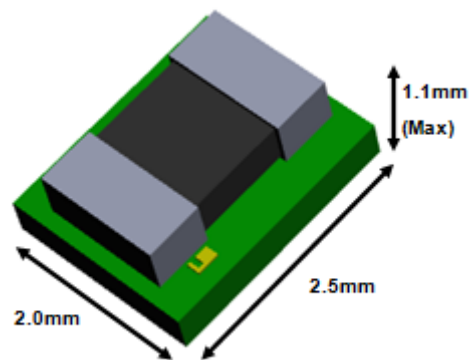

FIGURE 2 HIGH DENSITY LOW PROFILE  
uPOL MODULE

## ORDERING INFORMATION:

CAUTION: These devices have limited built-in ESD protection. The leads should be shorted together or the devices placed in conductive foam during the storage or handling to prevent electrostatic damage to internal circuit.

| PART NUMBER  | OUTPUT VOLTAGE | MARKING<br>(Code: X) | ORDERING     | QUANTITY |
|--------------|----------------|----------------------|--------------|----------|
| MUN3C1BR6-MB | 1.2V           | B                    | MUN3C1BR6-MB | 2000     |
| MUN3C1HR6-MB | 1.8V           | H                    | MUN3C1HR6-MB | 2000     |

## PACKAGE MARKING INFORMATION:

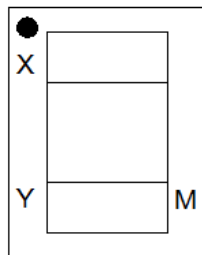

TOP VIEW

### Code:

- X – Output Voltage Specific
- Y – Year
- M - Month



## MUN3C1BR6-MB/ MUN3C1HR6-MB

### ELECTRICAL SPECIFICATIONS:

CAUTION: Do not operate at or near absolute maximum rating listed for extended periods of time. This stress may adversely impact product reliability and result in failures outside of warranty.

| Parameter                          | Description   | Min. | Typ. | Max.    | Unit |
|------------------------------------|---|------|------|---------|------|
| ■ Absolute Maximum Ratings         |   |      |      |         |      |
| VIN to GND                         |   | -    | -    | +6.0    | V    |
| VOUT to GND                        |   | -    | -    | +6.0    | V    |
| EN to GND                          |   | -    | -    | VIN+0.3 | V    |
| Tc                                 | Case Temperature of Inductor                          | -    | -    | +110    | °C   |
| Tj                                 | Junction Temperature                                  | -40  | -    | +150    | °C   |
| Tstg                               | Storage Temperature                                   | -40  | -    | +125    | °C   |
| ESD Rating                         | Human Body Model (HBM)                                | -    | -    | 2k      | V    |
|                                    | Machine Model (MM)                                    | -    | -    | 200     | V    |
|                                    | Charge Device Model (CDM)                             | -    | -    | 1k      | V    |
| ■ Recommendation Operating Ratings |   |      |      |         |      |
| VIN                                | Input Supply Voltage                                  | +2.7 | -    | +5.5    | V    |
| Ta                                 | Ambient Temperature                                   | -40  | -    | +85     | °C   |
| ■ Thermal Information              |   |      |      |         |      |
| Rth(jchoke-a)                      | Thermal resistance from junction to ambient. (Note 1) | -    | 76   | -       | °C/W |

NOTES:

1. Rth(jchoke-a) is measured with the component mounted on an effective thermal conductivity test board on 0 LFM condition. The test board size is 30mm×30mm×1.6mm with 2 layers. The test condition is compliant with JEDEC EIJ/JESD 51 Standards.

**ELECTRICAL SPECIFICATIONS: (Cont.)**

 Conditions:  $T_A = 25\text{ }^\circ\text{C}$ ,  $V_{in} = 3.3\text{V}$ ,  $C_{in} = 4.7\mu\text{F}/6.3\text{V}/0603$ ,  $C_{out} = 10\mu\text{F}/6.3\text{V}/0402$  unless otherwise specified.

| Symbol                                  | Parameter                       | Conditions  | Min.  | Typ. | Max. | Unit           |    |
|---|---------------------------------|---|---|------|------|----------------|----|
| <b>■ Input Characteristics</b>          |                                 |   |   |      |      |                |    |
| $I_{SD(IN)}$                            | Input shutdown current          | $V_{in} = 3.3\text{V}$ ,<br>$V_{in}$ connected EN by 100K ohm<br>EN = GND         | -   |      | -    | uA             |    |
|   |                                 | $V_{out}=1.2\text{ V}$  |   | 50   |      |                |    |
|   |                                 | $V_{out}=1.8\text{ V}$  |   | 50   |      |                |    |
| $I_{Q(IN)}$                             | Input supply bias current       | $V_{in} = 3.3\text{V}$ , $I_{out} = 0\text{A}$<br>EN = VIN                        | -   |      |      | uA             |    |
|   |                                 | $V_{out}=1.2\text{ V}$  |   | 20   |      |                |    |
|   |                                 | $V_{out}=1.8\text{ V}$  |   | 24   |      |                |    |
| $I_{S(IN)}$                             | Input supply current            | $V_{in} = 3.3\text{V}$ , EN = VIN<br>$I_{out} = 5\text{mA}$                       |   |      |      | mA             |    |
|   |                                 | $V_{out}=1.2\text{ V}$  |   | 2.5  |      |                |    |
|   |                                 | $V_{out}=1.8\text{ V}$  |   | 3.4  |      |                |    |
|   |                                 | $V_{in} = 3.3\text{V}$ , EN = VIN<br>$I_{out} = 100\text{mA}$                     |   |      |      | mA             |    |
|   |                                 | $V_{out}=1.2\text{ V}$  |   | 47   |      |                |    |
|   |                                 | $V_{out}=1.8\text{ V}$  |   | 68   |      |                |    |
|   |                                 |   | $V_{in} = 3.3\text{V}$ , EN = VIN<br>$I_{out} = 600\text{mA}$ |      |      |                | mA |
|   |                                 | $V_{out}=1.2\text{ V}$  |   | 306  |      |                |    |
|   |                                 | $V_{out}=1.8\text{ V}$  |   | 420  |      |                |    |
| <b>■ Output Characteristics</b>         |                                 |   |   |      |      |                |    |
| $I_{OUT(DC)}$                           | Output continuous current range | $V_{in}=3.3\text{V}$ , $V_{out}=1.2\text{V}/1.8\text{V}$                          | 0   | -    | 600  | mA             |    |
| $V_{O(SET)}$                            | Output Voltage Set Point        | $V_{in}=3.3\text{V}$  | -3.0  |      | +3.0 | % $V_{O(SET)}$ |    |
| $\frac{\Delta V_{OUT}}{\Delta V_{IN}}$  | Line regulation accuracy        | $V_{in} = 3.3\text{V}$ to 5V<br>$I_{out} = 0\text{A}$<br>$I_{out} = 600\text{mA}$ | -   | 0.1  | 0.2  | % $V_{O(SET)}$ |    |
| $\frac{\Delta V_{OUT}}{\Delta I_{OUT}}$ | Load regulation accuracy        | $I_{out} = 0\text{A}$ to 600mA<br>$V_{in} = 3.3\text{V}$ ,                        | -   | 0.5  | 1.0  | % $V_{O(SET)}$ |    |

## ELECTRICAL SPECIFICATIONS: (Cont.)

Conditions:  $T_A = 25\text{ }^\circ\text{C}$ ,  $V_{in} = 3.3\text{V}$ ,  $C_{in} = 4.7\mu\text{F}/6.3\text{V}/0603$ ,  $C_{out} = 10\mu\text{F}/6.3\text{V}/0603$  unless otherwise specified.

| Symbol                           | Parameter                             | Conditions  | Min.  | Typ.  | Max.  | Unit             |
|----------------------------------|---------------------------------------|---|-------|-------|-------|------------------|
| <b>■ Output Characteristics</b>  |                                       |   |       |       |       |                  |
| $V_{OUT(AC)}$                    | Output ripple voltage                 | $V_{in} = 3.3\text{V}$ , $EN = VIN$<br>$I_{out} = 0\text{ mA}$  |       |       |       | mV               |
|                                  |                                       | $V_{out} = 1.2\text{ V}$  |       | 15    |       |                  |
|                                  |                                       | $V_{out} = 1.8\text{ V}$  |       | 19    |       |                  |
|                                  |                                       | $V_{in} = 3.3\text{V}$ , $EN = VIN$<br>$I_{out} = 600\text{mA}$ |       |       |       | -<br>mV          |
|                                  |                                       | $V_{out} = 1.2\text{ V}$  |       | 10    |       |                  |
|                                  |                                       | $V_{out} = 1.8\text{ V}$  |       | 13    |       |                  |
| $C_{OUT(MAX)}$                   | Maximum capacitive load               | $I_{out} = 600\text{mA}$ , $ESR \geq 1\text{ m}\Omega$          |       |       | 22    | $\mu\text{F}$    |
| <b>■ Control Characteristics</b> |                                       |   |       |       |       |                  |
| $V_{REF}$                        | Reference voltage                     |   | 0.588 | 0.600 | 0.612 | V                |
| $F_{OSC}$                        | Oscillator frequency                  | PWM Operation   | 1.2   | 1.5   | 1.8   | MHz              |
| $V_{EN\_TH}$                     | Enable rising threshold voltage       |   | 1.2   | -     | -     | V                |
|                                  | Enable falling threshold voltage      |   | -     | -     | 0.4   | V                |
| <b>■ Fault Protection</b>        |                                       |   |       |       |       |                  |
| $V_{UVLO\_TH}$                   | Input under voltage lockout threshold | Falling   | -     | 1.8   | -     | V                |
| $T_{OTP}$                        | Over temp protection                  |   | -     | 160   | -     | $^\circ\text{C}$ |
| $I_{LIMIT\_TH}$                  | Current limit threshold               | Peak value of inductor current,                                 | -     | 1.5   | 2.3   | A                |

## PIN CONFIGURATION:

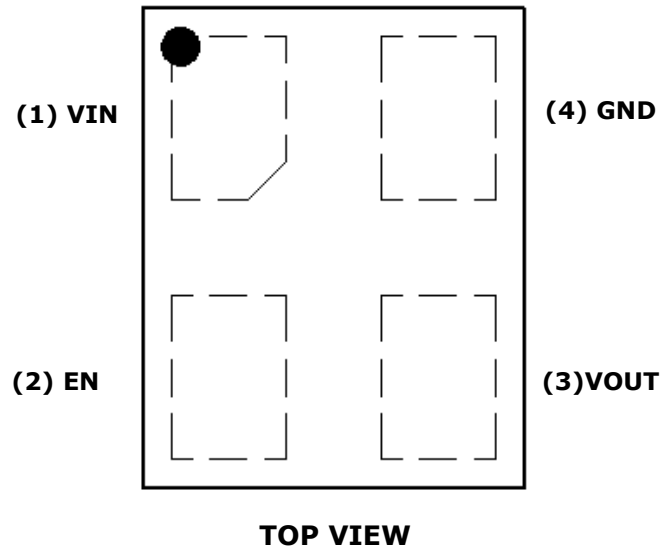

## PIN DESCRIPTION:

| Symbol | Pin No. | Description   |
|--------|---------|---|
| VIN    | 1       | Power input pin. It needs to be connected to input rail with input capacitor. A 4.7uF capacitor at least for input.   |
| EN     | 2       | On/Off control pin for module.<br>EN = LOW, the module is off.<br>EN = HIGH, the module is on.  |
| VOUT   | 3       | Power output pin. Connect to output for the load with output capacitor. A 10uF capacitor at least for output.   |
| GND    | 4       | Power ground pin for signal, input, and output return path. This pin needs to be connected to one or more ground plane directly. Connect to thermal exposed pad of GND for heat transferring. |

## TYPICAL PERFORMANCE CHARACTERISTICS: (1.2VOUT)

Conditions:  $T_A = 25\text{ }^\circ\text{C}$ , unless otherwise specified. Test Board Information: 30mm×30mm×1.6mm, 2 layers. The output ripple and transient response are measured by short loop probing and limited to 20 MHz bandwidth. The following figures are the typical characteristic curves at 1.2Vout.

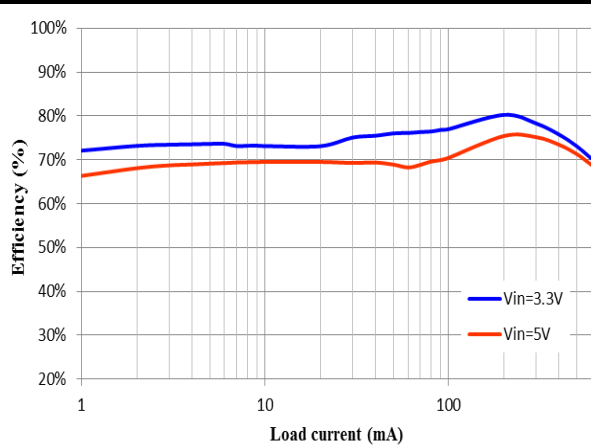

**FIGURE 3 EFFICIENCY V.S. LOAD CURRENT**

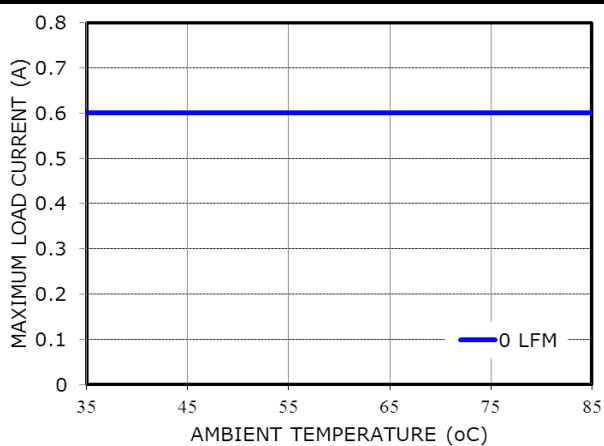

**FIGURE 4 DE-RATING CURVE AT 3.3VIN**

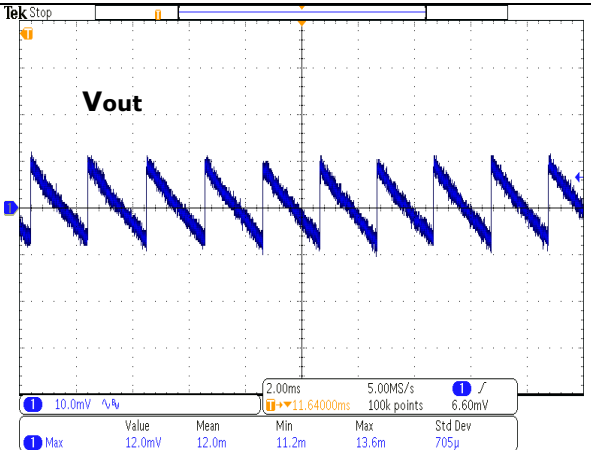

**FIGURE 5 OUTPUT RIPPLE (3.3VIN, IOUT=0A)**

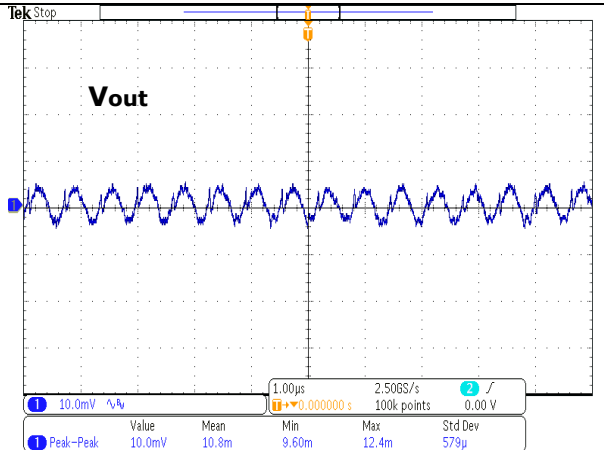

**FIGURE 6 OUTPUT RIPPLE (3.3VIN, IOUT=600mA)**

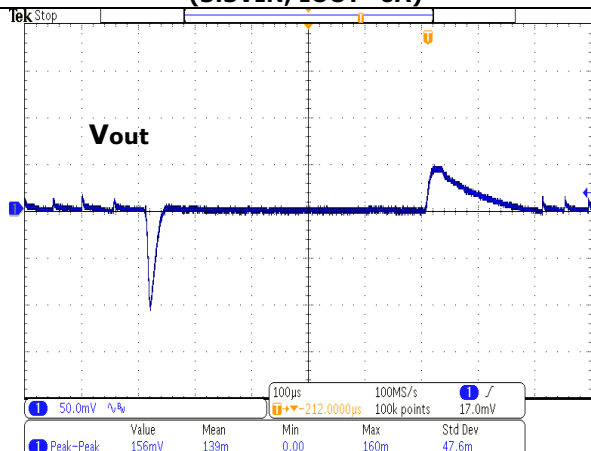

**FIGURE 7 TRANSIENT RESPONSE (3.3VIN, 0% to 50% LOAD STEP)**

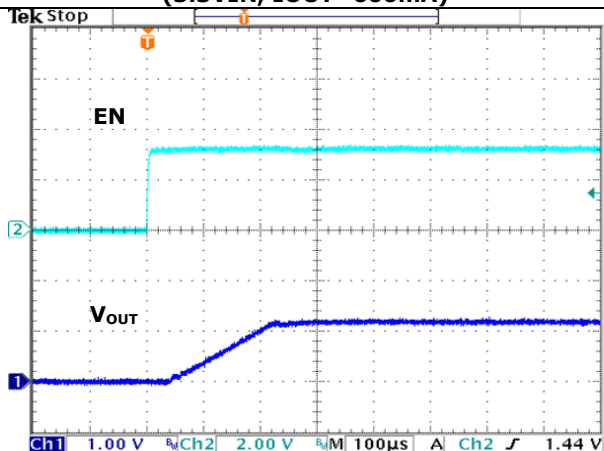

**FIGURE 8 TURN-ON (3.3VIN, IOUT=600mA)**

## TYPICAL PERFORMANCE CHARACTERISTICS: (1.8VOUT)

Conditions:  $T_A = 25^\circ\text{C}$ , unless otherwise specified. Test Board Information: 30mm×30mm×1.6mm, 2 layers. The output ripple and transient response are measured by short loop probing and limited to 20MHz bandwidth. The following figures are the typical characteristic curves at 1.8Vout.

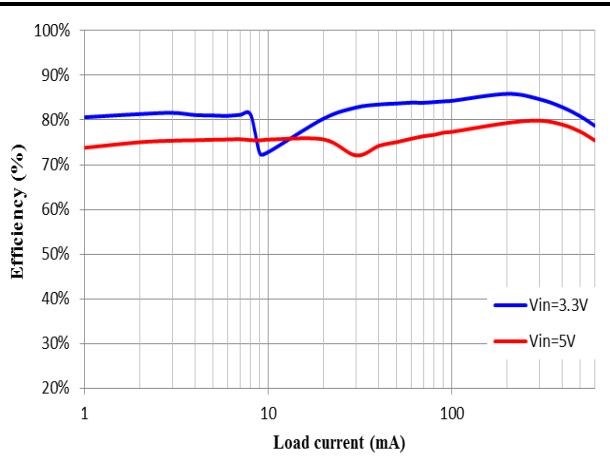

FIGURE 9 EFFICIENCY V.S. LOAD CURRENT

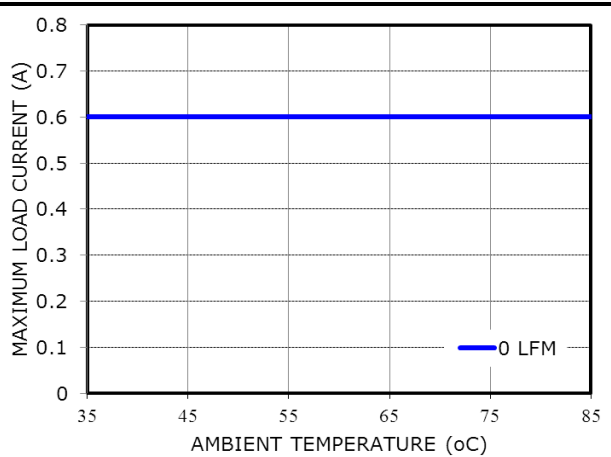

FIGURE 10 DE-RATING CURVE AT 3.3VIN

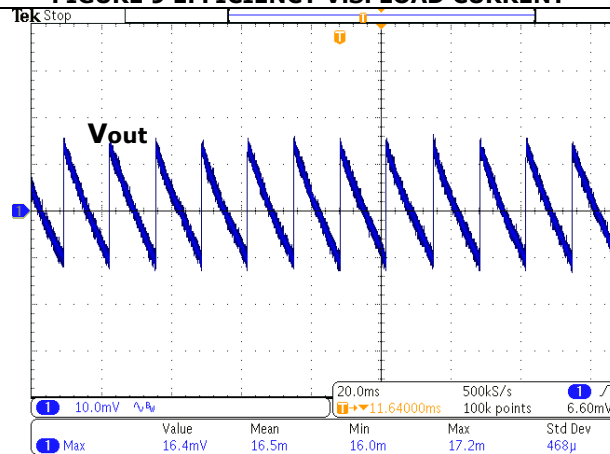

FIGURE 11 OUTPUT RIPPLE (3.3VIN, IOUT=0A)

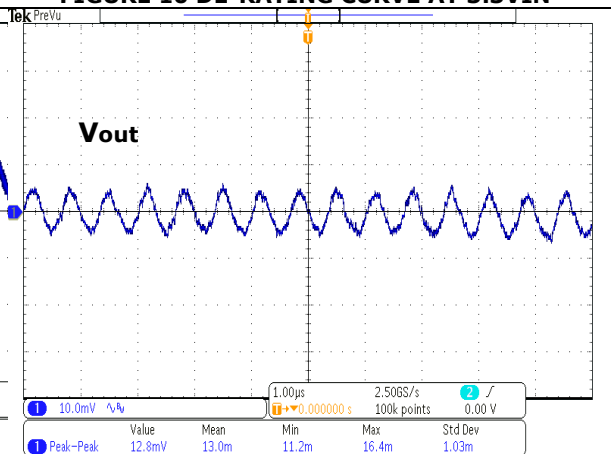

FIGURE 12 OUTPUT RIPPLE (3.3VIN, IOUT=600mA)

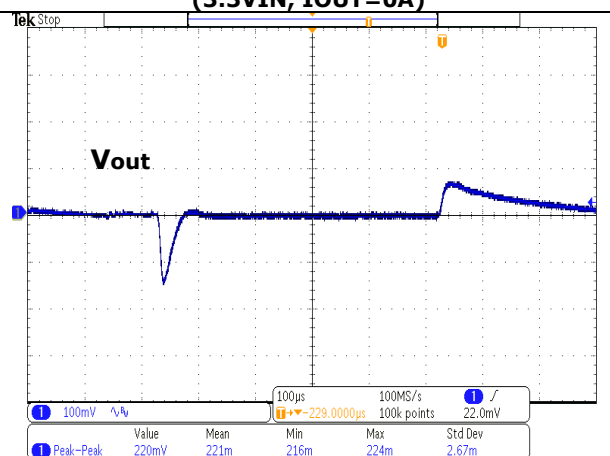

FIGURE 13 TRANSIENT RESPONSE (3.3VIN, 0% to 50% LOAD STEP)

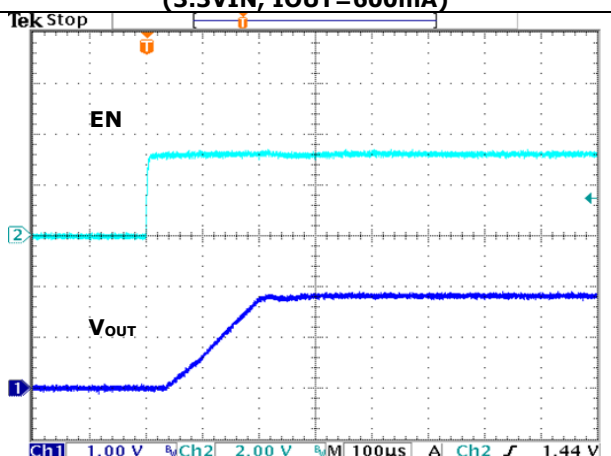

FIGURE 14 TURN-ON (3.3VIN, IOUT=600mA)



## APPLICATIONS INFORMATION:

### REFERENCE CIRCUIT FOR GENERAL APPLICATION:

The Figure 15 shows the module application schematics for input voltage +5V or +3.3V and turn on by input voltage directly through enable resistor (Ren).

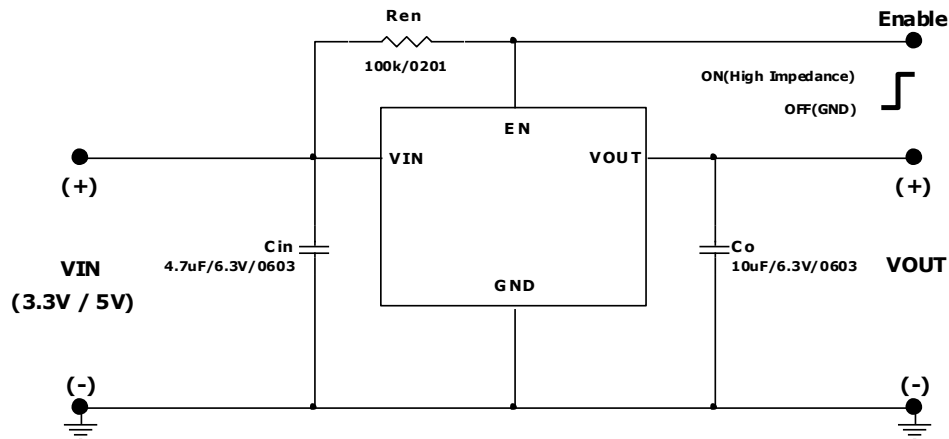

**FIGURE 15 GENERAL APPLICATION CIRCUIT WITH TURN-ON BY INPUT VOLTAGE**

### SAFETY CONSIDERATIONS:

Certain applications and/or safety agencies may require fuses at the inputs of power conversion components. Fuses should also be used when there is the possibility of sustained input voltage reversal which is not current limited. For greatest safety, we recommend a fast blow fuse installed in the ungrounded input supply line. The installer must observe all relevant safety standards and regulations. For safety agency approvals, install the converter in compliance with the end-user safety standard.

### INPUT FILTERING:

The module should be connected to a source supply of low AC impedance and high inductance in which line inductance can affect the module stability. An input capacitor must be placed as near as possible to the input pin of the module so to minimize input ripple voltage and ensure module stability.

### OUTPUT FILTERING:

To reduce output ripple and improve the dynamic response as the step load changes, an additional capacitor at the output must be connected. Low ESR polymer and ceramic capacitors are recommended to improve the output ripple and dynamic response of the module.

## APPLICATIONS INFORMATION: (Cont.)

### Thermal Considerations:

All of thermal testing condition is complied with JEDEC EIJ/JESD 51 Standards. Therefore, the test board size is 30mm×30mm×1.6mm with 2 layers. The case temperature of module sensing point is shown as Figure 16. Then  $R_{th(j_{choke}-a)}$  is measured with the component mounted on an effective thermal conductivity test board on 0 LFM condition. The MUN3C1BR6-MB/MUN3C1HR6-MB modules are designed for using when the case temperature is below 110°C regardless the change of output current, input/output voltage or ambient temperature.

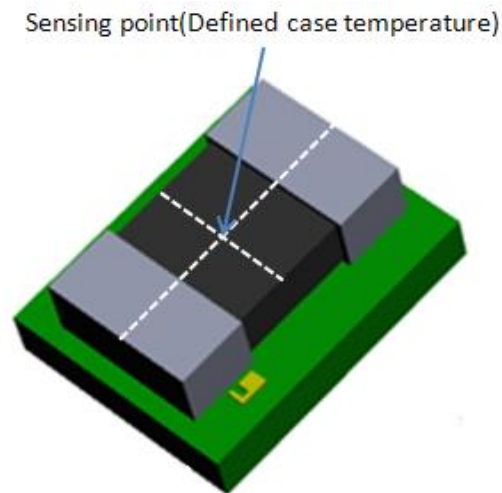

**Figure 16. Case Temperature Sensing Point**

**PACKAGE OUTLINE DRAWING:**

Unit: mm

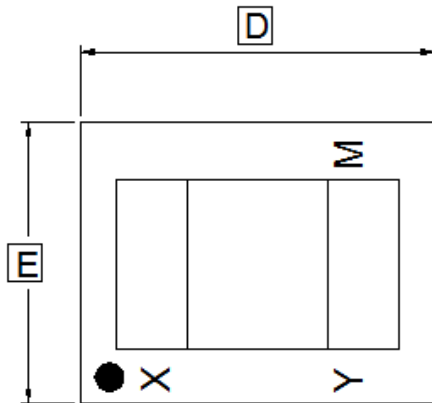

TOP VIEW

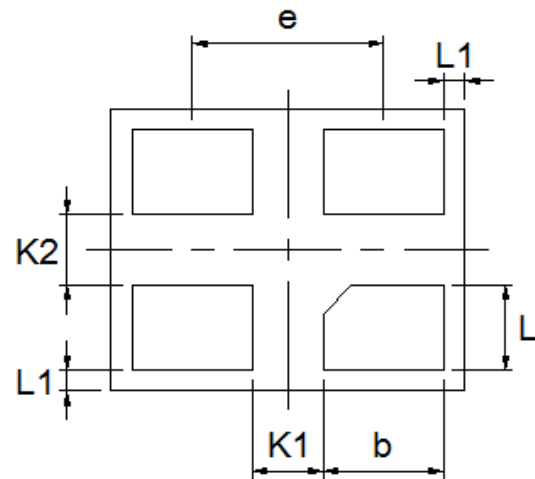

BOTTOM VIEW

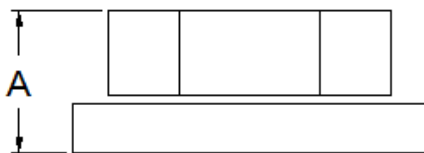

SIDE VIEW

| DIM | MILLIMETERS |      |      |
|-----|-------------|------|------|
|     | MIN         | NOM  | MAX  |
| A   | 0.80        | 0.95 | 1.10 |
| b   | 0.75        | 0.85 | 0.95 |
| D   | 2.35        | 2.5  | 2.65 |
| E   | 1.85        | 2    | 2.15 |
| e   | 1.25        | 1.35 | 1.45 |
| K1  | 0.40        | 0.5  | 0.60 |
| K2  | 0.40        | 0.5  | 0.60 |
| L   | 0.50        | 0.60 | 0.70 |
| L1  | 0.00        | 0.15 | 0.30 |

LAND PATTERN REFERENCE:

Unit: mm

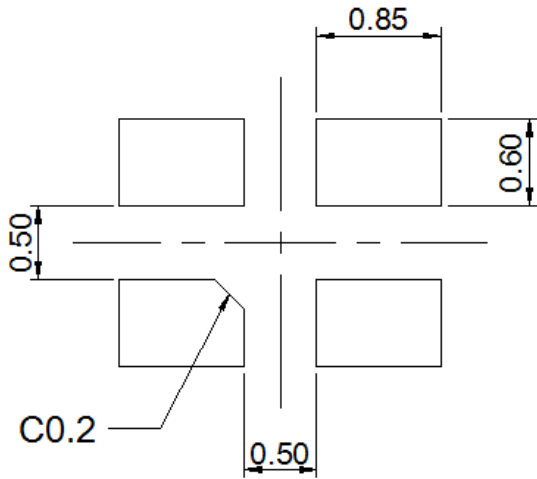

RECOMMENDED LAND PATTERN

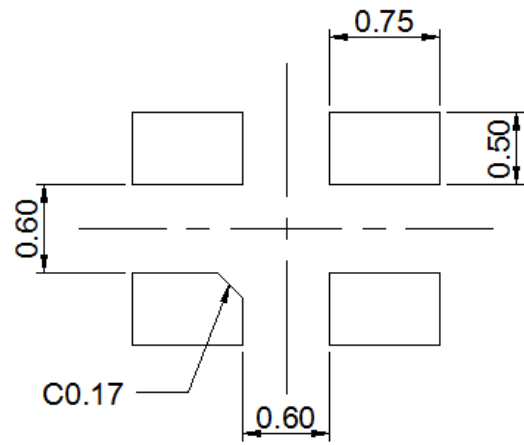

RECOMMENDED STENCIL PATTERN  
BASED ON 100μm THICKNESS STENCIL

**PACKING REFERENCE:**

Unit: mm

### Package In Tape Loading Orientation

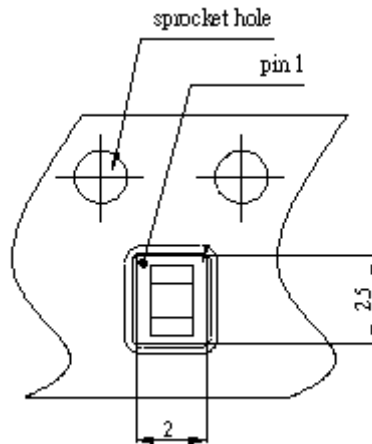

### Tape Dimension

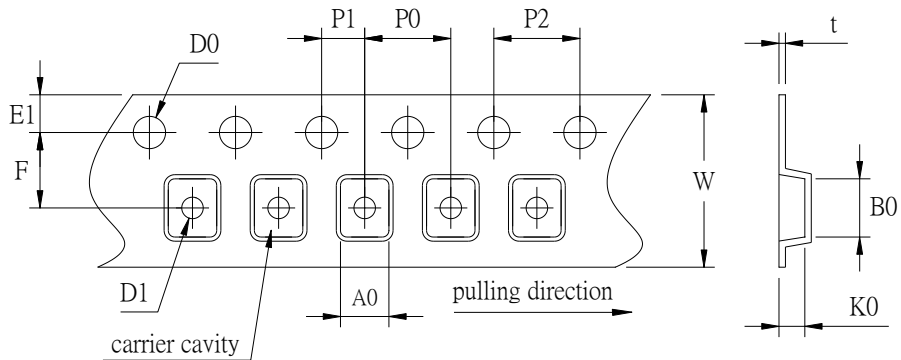

|    |                         |    |                 |
|----|-------------------------|----|-----------------|
| A0 | $2.32 \pm 0.10$         | E1 | $1.75 \pm 0.10$ |
| B0 | $2.82 \pm 0.10$         | K0 | $1.15 \pm 0.10$ |
| F  | $3.50 \pm 0.05$         | P0 | $4.00 \pm 0.10$ |
| W  | $8.00 +0.30/-0.10$      | P1 | $2.00 \pm 0.05$ |
| D0 | $\phi 1.50 +0.1/-0.0$   | P2 | $4.00 \pm 0.10$ |
| D1 | $\phi 1.0 \text{ Min.}$ | t  | $0.25 \pm 0.05$ |

**PACKING REFERENCE: (Cont.)**

Unit: mm

**Reel Dimension**

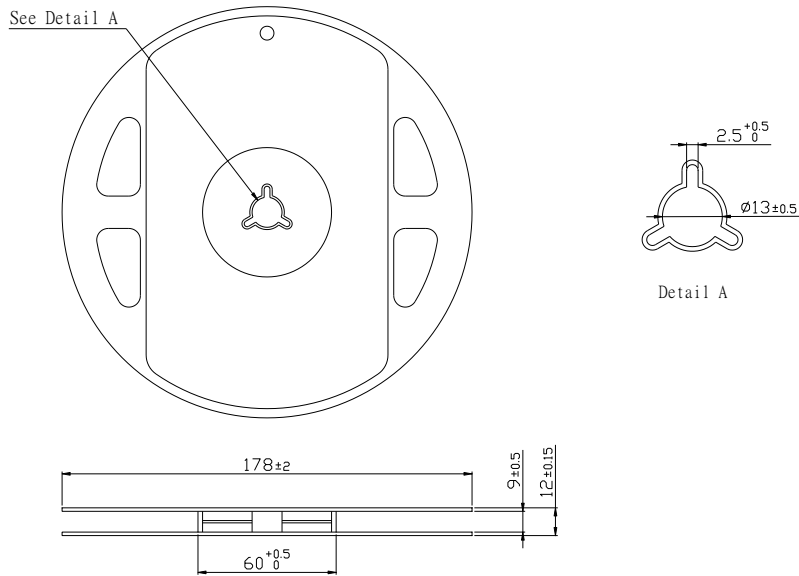

**Peel Strength of Top Cover Tape**

The peel speed shall be about 300mm/min.

The peel force of top cover tape shall be between 0.1N to 1.0N

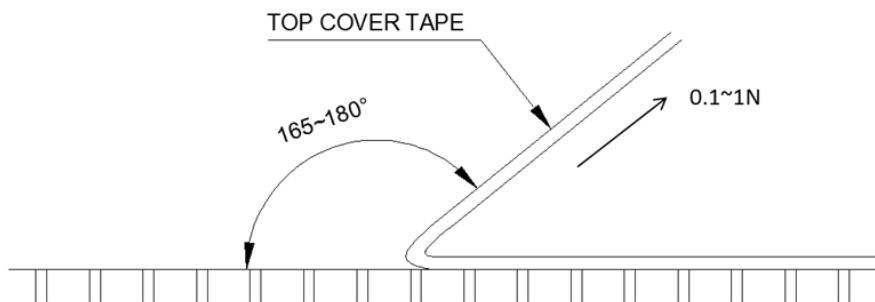



## MUN3C1BR6-MB/ MUN3C1HR6-MB

### REVISION HISTORY:

| Date       | Revision | Changes                                     |
|------------|----------|---|
| 2014.09.16 | 00       | Initial released for preliminary datasheet. |
| 2014.10.30 | 01       | Add part number MUN3C1HR6-MB                |
| 2014.12.04 | 02       | Add $R_{th}$ ,De-rating curve               |
| 2014.12.29 | 03       | Update uPOL to LDS                          |
| 2016.12.14 | 04       | Update LDS to uPOL                          |
| 2017.05.16 | 05       | Update output voltage marking code          |