



DATA SHEET

(DOC No. HM0360-MWA-00FW703-DS)

➤➤ **HM0360-MWA-00FW703**

Compact Camera Module

Preliminary version 01 April, 2021

>> HM0360-MWA-00FW703

Compact Camera Module



Himax Imaging, Ltd.

<http://www.himax.com.tw>

Revision History

April, 2021

Version	Date	Description of changes
01	2021/04/28	New setup.

Himax Imaging, Ltd.
Confidential
Do Not Copy

List of Contents

April, 2021

1. Sensor Specification 7
1.1. Features 8
1.2. Application 8
1.3. Key parameters 9
1.4. VGA window readout 10
1.5. Electrical specification 11
1.5.1. Operating voltages 11
1.5.2. DC characteristics 11
1.5.3. Master Clock (MCLK) input 12
1.6. Power up sequence 13
2. Camera Module Specification 14
2.1. Pin map and description of camera module 14
2.2. Mechanical drawing of camera module 15
2.3. Application schematic of camera module 16
2.3.1. Reference circuit 16
2.3.2. Layout consideration 16
3. Optical Lens Specification 17
3.1. Mechanical drawing of optical lens 17
3.2. Specification of optical lens 17
4. Image Quality Specification 18
5. Reliability Test Conditions 19
6. Inspection Specification 20
6.1. Sampling plan 20
6.2. Visual inspection method 20
6.3. Inspection item 20
6.4. Remark 20
6.5. Appearance / Dimension check 21

Himax Imaging, Ltd. Confidential Do Not Copy

List of Figures

April, 2021

Figure 1.1: VGA resolution pixel readout	10
Figure 1.2: Power up sequence	13
Figure 2.1: Mechanical drawing of camera module	15
Figure 2.2: Reference circuit of camera module (CSP)	16
Figure 3.1: Mechanical drawing of optical lens	17

Himax Imaging, Ltd.
Confidential
Do Not Copy

>> HM0360-MWA-00FW703

Compact Camera Module



Himax Imaging, Ltd.

<http://www.himax.com.tw>

List of Tables

April, 2021

Table 1.1: Operating voltages	11
Table 1.2: DC characteristics	12
Table 1.3: Master Clock (MCLK) timing	12
Table 1.4: Power up sequence timing	13
Table 2.1: Pin map and description of camera module	14
Table 3.1: Specification of optical lens	17
Table 4.1: Image quality specification	18
Table 5.1: Reliability test condition	19

Himax Imaging, Ltd.
Confidential
Do Not Copy

HM0360-MWA-00FW703

Compact Camera Module



Himax Imaging, Ltd.

<http://www.himax.com.tw>

Important Notice

April, 2021

Disclaimer

Himax Imaging reserves the right to modify this documentation without prior notice. The information appearing in this publication is believed to be accurate and reliable. However, Himax Imaging makes no warranty for any errors which may appear in this document. Contact Himax Imaging to obtain the latest version of product specifications before placing your order. No responsibility is assumed by Himax Imaging, Ltd. for any infringement of patent or other rights of third parties which may result from its use. Products described herein are intended for use in normal commercial applications. Please note that application circuits illustrated in this document are for reference purposes only.

All Rights Reserved

The following are trademarks of Himax Imaging Ltd.: Himax Imaging, BrightSense, ClearSense, the Himax Imaging logo symbol. The use of any trademark, trade name, or service mark found in this document without the owner's express written consent is strictly prohibited.

Himax Imaging strives to produce quality documentation and welcomes your feedback. Please send comments or suggestions to hi_marketing@himaximaging.com.

Himax Imaging, Ltd.
Confidential
Do Not Copy

1. Sensor Specification

The HM0360 is an ultra-low power, Back Side Illuminated (BSI) CMOS image sensor designed for energy efficient smart vision applications, such as object-specific classification, tracking and identification. The advanced 3.6μ low noise, deep diode pixel achieves superior image quality performance to enable monitoring, detection and video capture in low light environments while minimizing the use of external, power consuming, LED illuminators.

The HM0360 Always On Sensor architecture delivers a target current consumption of $256\mu\text{A}$ in AoS monitor mode and 8.6mA in VGA 60 frames per second read out mode. In order to reduce host processor loading, camera latency and system power consumption, the HM0360 features on-chip oscillator with automatic external reference clock detection, automatic frame mode switch, fast sensor initialization, $<2\text{ms}$ frame trigger time, context switching and instant frame update. The sensor offers several monitoring options with programmable interrupt thereby allowing the host processor to be placed in low power standby until notified by the sensor.

The HM0360 is available in a compact Chip Scale Package (CSP) compatible with standard SMT reflow process. The sensor supports multiple power supply configurations and uses few passive components to enable a highly compact camera module design for next generation energy efficient, smart camera devices.

Himax Imaging, Ltd. Confidential
Do Not

1.1. Features

- Ultra Low Power, high sensitivity, low noise VGA sensor
- Operates 8.6mA VGA 60 FPS down to 256 μ A in monitor mode
- Automatic wake and sleep operation with programmable event interrupt to wake host processor
- On chip high precision oscillator, auto exposure / gain, ambient light sensor and zone detection
- Metered exposure provides well exposed first frame and after extended sleep (blinking) period
- External frame synch and stereo camera support
- Flexible binning, subsampling and region of interest
- Embedded line provides metadata frame, AE statistics, zone trigger and other interrupt event information
- On-chip high precision oscillator and LDO
- 1-lane MIPI CSI2 and 8-bit parallel/serial data format that supports 1-bit, 4-bit and 8-bit protocol
- I2C 2-wire serial interface supporting burst operation for fast register access
- < 13 mm² CSP sensor package option
- High CRA for low profile module design

1.2. Application

- Cellular and mobile phones
- Digital video camcorders
- PC multimedia
- Tablets

Himax Imaging, Ltd.
Confidential
Do Not Copy

1.3. Key parameters

Parameters		Value
Image sensor part number		HM0360-MWA
Pixel array (Active / Effective)		656 x 496 / 640 x 480
Pixel size		3.6 μ m x 3.6 μ m / BSI
Image diagonal		2.88mm (1/6")
Color filter array		Bayer, Monochrome
Shutter type		Electronic Rolling Shutter
Frame rate @24MHz		QQVGA 1 FPS to VGA 60 FPS
S/N ratio (Max.)		45.5 dB
Dynamic range (1x)		60 dB
Sensitivity		5.5V / Lux-sec @530nm 15V / (μ W-cm ² sec) @850nm
Pixel CRA (Max.)		35.74°
Supply voltage	AVDD	2.8V
	DVDD	1.2V (Internal LDO)
	IOVDD	1.8V / 2.8V
Input reference clock		6 – 24MHz
Internal oscillator		48MHz
Serial interface		I2C (1MHz max., single / burst)
MIPI data format		8-bit
Parallel / Serial data format		8-bit, 4-bit+4-bit / 4-bit / 1-bit
Current Consumption (8-bit parallel interface, Typ.)		QVGA(S2), 2FPS: 179 μ A QVGA, 60FPS: 5.25 mA VGA, 60FPS: 8.6 mA
Temperature		Operating -40 °C to 85 °C Stable Image 0 °C to 60 °C
Construction		3P
EFL		1.56 mm
BFL		0.75 mm
Image circle		ψ 3.0 mm
F/No		2.4 \pm 5%
TV distortion		< 1.5%
Field of view	Horizontal	70.1°
	Vertical	55.4°
	Diagonal	85.0°
Relative illumination		>33% at y=1.0 field
Chief ray angle		< 28°
Barrel size		M4 x P0.3
Holder size		6.5mm x 6.5mm
Total track (Barrel to image)		Y=3.0mm

1.4. VGA window readout

The HM0360 full active pixel array of 656 x 496 can be windowed to 640 x 480 by register **0x3030[0]**.

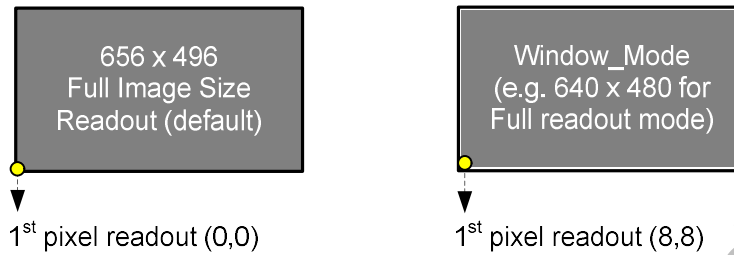

Figure 1.1: VGA resolution pixel readout

Himax Imaging, Ltd.
Confidential
Do Not Copy

1.5. Electrical specification

1.5.1. Operating voltages

Parameter	Symbol	Spec.			Unit
		Min.	Typ.	Max.	
Analog supply voltage	V _{DD-A}	2.6	2.8	3.0	V
Digital supply voltage	V _{DD-D}	1.08	1.2	1.32	V
IO supply voltage	V _{DD-IO}	1.7	1.8 / 2.8	3.0	V
LDO supply voltage	V _{DD-LDOIN}	1.7	1.8 / 2.8	3.0	V

Table 1.1: Operating voltages

1.5.2. DC characteristics

The power consumptions are measured in color bar (C_L = 5pF).

Parameter	Symbol	Condition	Spec.			Unit
			Min.	Typ.	Max.	
Average Current Consumption – Parallel 8b, External LDO mode						
Continuous video output	I _{DD-AVDD1}	Video, VGA @ 60 FPS, PCLKO free running, V _{DD-A} = 2.8V, V _{DD-D} = 1.2V, V _{DD-IO} = 1.8V	-	1940	-	μA
	I _{DD-DVDD1}		-	4860	-	μA
	I _{DD-IOVDD1}		-	1790	-	μA
S1 (Gate single frame with software standby)	I _{DD-AVDD1}	Auto wake up sleep, QQVGA@ 2 FPS, PCLKO gated, V _{DD-A} = 2.8V, V _{DD-D} = 1.2V, V _{DD-IO} = 1.8V, XSLEEP high	-	36.6	-	μA
	I _{DD-DVDD1}		-	215.6	-	μA
	I _{DD-IOVDD1}		-	4	-	μA
S2 (Gate single frame with hardware standby)	I _{DD-AVDD1}	Auto wake up sleep, QQVGA@ 2 FPS, PCLKO gated, V _{DD-A} = 2.8V, V _{DD-D} = 1.2V, V _{DD-IO} = 1.8V, XSLEEP control by host	-	22.6	-	μA
	I _{DD-DVDD1}		-	70.1	-	μA
	I _{DD-IOVDD1}		-	2.5	-	μA
Software Standby current	I _{DD-SLEEP1}	V _{DD-A} = 2.8V, V _{DD-D} = 1.2V, V _{DD-IO} = 1.8V XSLEEP inactive	-	176	-	μA
Hardware Standby current	I _{DD-SLEEP2}	V _{DD-A} = 2.8V, V _{DD-D} = 1.2V, V _{DD-IO} = 1.8V XSLEEP active	-	16	-	μA
Average Current Consumption – MIPI, External LDO mode						
Continuous video output	I _{DD-AVDD1}	Video, VGA @ 60 FPS, gated by line, w/o LSLE V _{DD-A} = 2.8V, V _{DD-D} = 1.2V, V _{DD-IO} = 1.8V	-	2120	-	μA
	I _{DD-DVDD1}		-	8840	-	μA
	I _{DD-IOVDD1}		-	1	-	μA
S1 (Gate single frame with software standby)	I _{DD-AVDD1}	Auto wake up sleep, QQVGA@ 2 FPS, gated by line, w/o LSLE V _{DD-A} = 2.8V, V _{DD-D} = 1.2V, V _{DD-IO} = 1.8V, XSLEEP high	-	42.4	-	μA
	I _{DD-DVDD1}		-	224.2	-	μA
	I _{DD-IOVDD1}		-	4.5	-	μA

Parameter	Symbol	Condition	Spec.			Unit
			Min.	Typ.	Max.	
S2 (Gate single frame with hardware standby)	I _{DD-AVDD1}	Auto wake up sleep, QQVGA@ 2 FPS, gated by line, w/o LSLE V _{DD-A} = 2.8V, V _{DD-D} = 1.2V, V _{DD-IO} = 1.8V, XSLEEP control by host	-	26.3	-	μA
	I _{DD-DVDD1}		-	75.7	-	μA
	I _{DD-IOVDD1}		-	2.5	-	μA
Software Standby current	I _{DD-SLEEP1}	V _{DD-A} = 2.8V, V _{DD-D} = 1.2V, V _{DD-IO} = 1.8V XSLEEP inactive	-	179	-	μA
Hardware Standby current	I _{DD-SLEEP2}	V _{DD-A} = 2.8V, V _{DD-D} = 1.2V, V _{DD-IO} = 1.8V XSLEEP active	-	17	-	μA
Average Current Consumption – Hardware shutdown						
Hardware shutdown (Parallel/MIPI)	I _{DD}	MCLK off	-	1	-	μA
Digital Inputs (MCLK, TRIGGER, SCL)						
Input voltage low	V _{IL}	-	GND – 0.3	-	0.3V _{DD-IO}	V
Input voltage high	V _{IH}	-	0.7V _{DD-IO}	-	V _{DD-IO} + 0.3	V
Digital Output						
Output voltage low	V _{OL}	-	-	-	0.2V _{DD-IO}	V
Output voltage high	V _{OH}	-	0.8V _{DD-IO}	-	-	V
Tri-state leakage current	I _{OZ}	-	-	-	10	μA

Table 1.2: DC characteristics

1.5.3. Master Clock (MCLK) input

Parameter	Symbol	Condition	Spec.			Unit
			Min.	Typ.	Max.	
Input frequency	MCLK	-	6	-	24	MHz
Input clock duty cycle	MCLK _{DUTY}	-	45	-	55	%

Table 1.3: Master Clock (MCLK) timing

1.6. Power up sequence

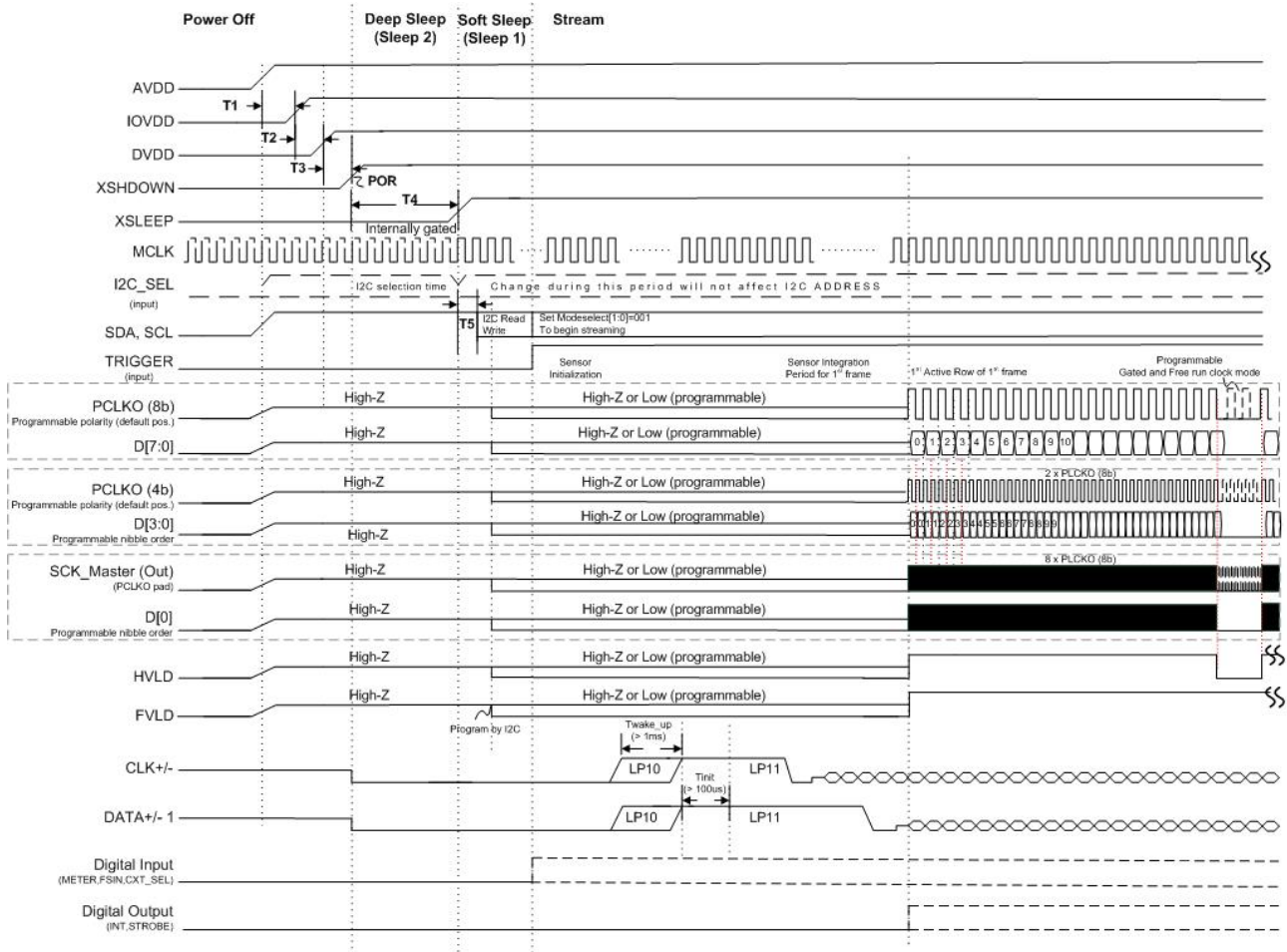

Figure 1.2: Power up sequence

Parameter	Symbol	Spec.			Unit
		Min.	Typ.	Max.	
AVDD to IOVDD	T1	0	-	∞	s
IOVDD to DVDD	T2	0	-	∞	s
DVDD to XSHDOWN (External DVDD)	T3	0	-	∞	s
XSHDOWN to XSLEEP	T4	400	-	-	µs
XSLEEP to 1 st I2C command	T5	38.6	-	-	µs

Note: (1) The minimum timing of T4 is 50µs when using external LDO mode.
 (2) The maximum timing for power on reset time (POR) is 50µs.

Table 1.4: Power up sequence timing

2. Camera Module Specification

2.1. Pin map and description of camera module

Pin no.	Pin name	Type	Description
1	AVDD	Power	Analog power. (2.8V)
2	AGND	Ground	Analog ground.
3	D7	Out	Data 7 output.
4	D6	Out	Data 6 output.
5	D5	Out	Data 5 output.
6	D4	Out	Data 4 output.
7	D3	Out	Data 3 output.
8	D2	Out	Data 2 output.
9	D1	Out	Data 1 output.
10	D0	Out	Data 0 output.
11	DGND	Ground	Digital ground.
12	IOVDD	Power	IO power. (1.8V)
13	DVDD	Power	Core digital power. (1.2V)
14	DGND	Ground	Digital ground.
15	MCLK	In	Master clock input.
16	PCLKO	Out	Pixel clock
17	CXT_SEL	In	Context switching selection. (Internal pull low)
18	INT	Out	Interrupt output. (Active high)
19	SDA	In/Out	Serial Data I/O. (Open drain)
20	SCL	In	I2C serial clock.
21	HVLD	Out	Line valid output.
22	FVLD	Out	Frame valid output.
23	TRIGGER	In	Frame trigger input. (Internal pull low / Active high)
24	DGND	Ground	Digital ground.
25	CLK_SEL	In	Clock source select. (Internal pull low, L: Oscillator; H: MCLK, connect to ground for oscillator mode)
26	RTC	In	Real time clock source input. (Must not be left floating, connected to DGND without RTC clock input)
27	METER	In	Exposure meter enable pin. (Internal pull low / Active high)
28	XSHUTDOWN	In	Reset and power down control pin. (Active low)
29	XSLEEP	In	Low power sleep mode. (Active low)
30	STROBE	Out	Strobe output.

Note: (1) HM0360 sensor default slave address: 0x24.

Table 2.1: Pin map and description of camera module

2.2. Mechanical drawing of camera module

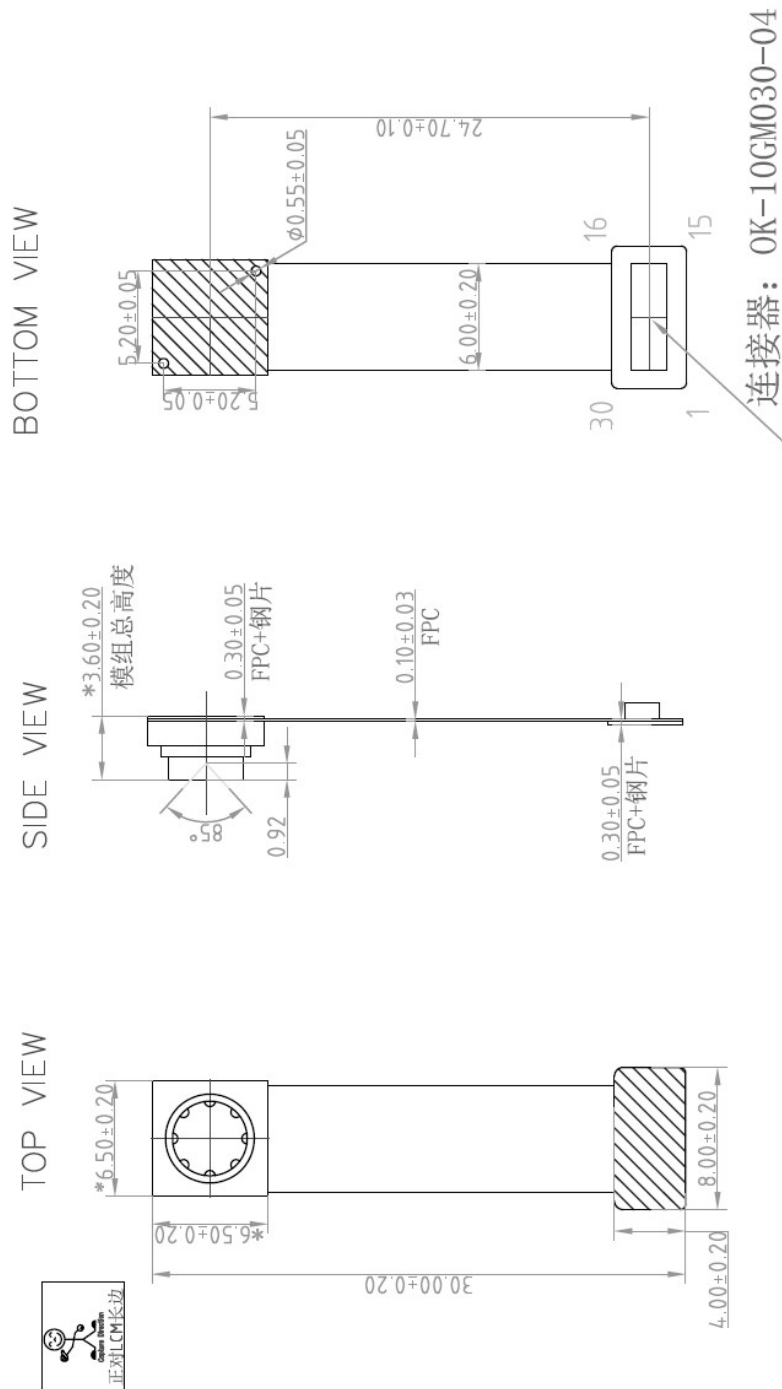

NO.	SYMBOL
1	AVDD
2	AGND
3	D7
4	D6
5	D5
6	D4
7	D3
8	D2
9	D1
10	D0
11	DGND
12	IOVDD
13	DVDD
14	DGND
15	MCLK
16	PCLKD
17	CXT_SEL
18	INT
19	SDA
20	SCL
21	HVLD
22	FVLD
23	TRIGGER
24	DGND
25	CKL_SEL
26	RTC
27	METER
28	XSHUTDOWN
29	XSLEEP
30	STROBE

Figure 2.1: Mechanical drawing of camera module

2.3. Application schematic of camera module

2.3.1. Reference circuit

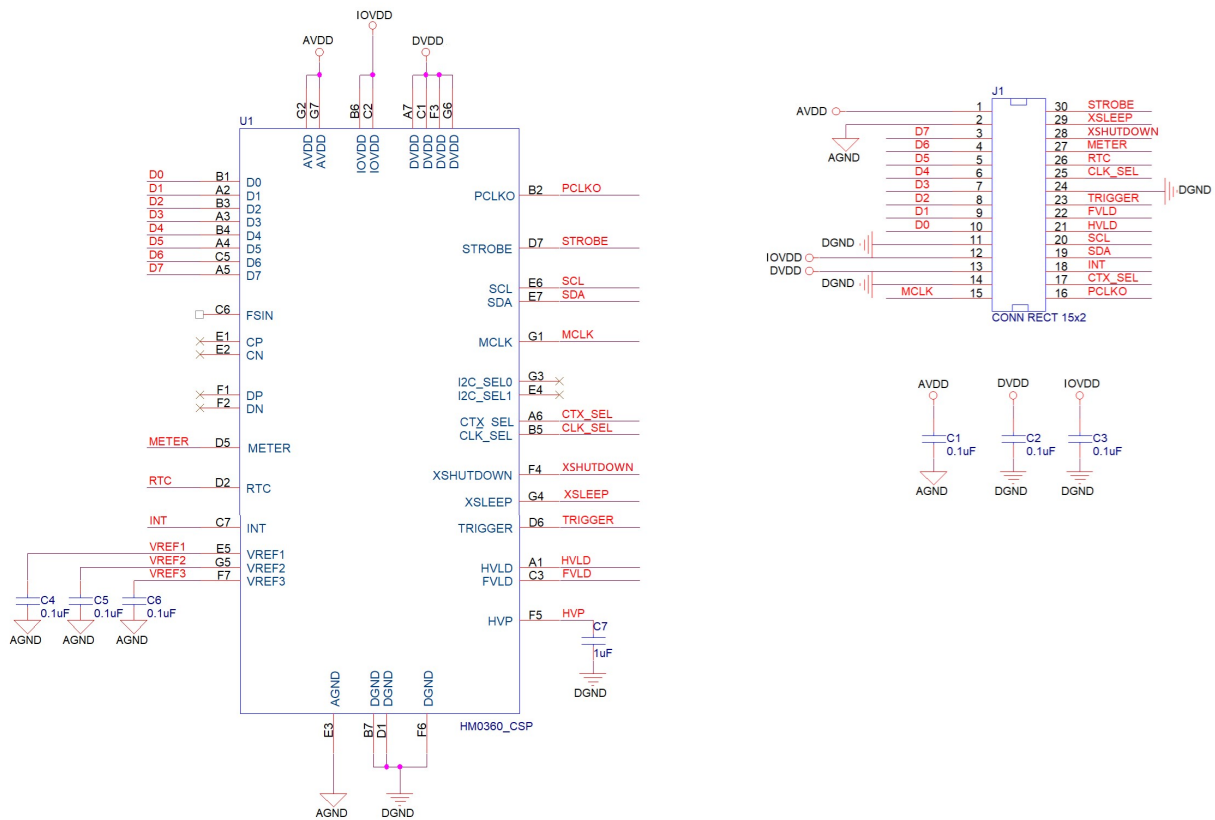

- Note:**
- (1) Capacitors should be placed close to its respective pin. All power supplies must be adequately decoupled.
 - (2) CCI pull-up resistors should have a value based on the CCI specification (**typically 4k7 ohm**).
 - (3) RTC pin must not be left floating, connected to DGND without RTC clock input.
 - (4) MCLK connect to DGND when using internal oscillator.

Figure 2.2: Reference circuit of camera module (CSP)

2.3.2. Layout consideration

- A. In order to reduce power noise to the camera module, it is suggested that a 0.1µF capacitor and a high value decoupling capacitor (**10µF or above**) be placed across every power line (**AVDD & DVDD & IOVDD**) and corresponding ground pin. Try to place these capacitors close to the module connector. The power noise will contribute to image noise and it is necessary to reduce them as much as possible.
- B. In order to reduce interference and noise caused by the high frequency clocks. It is suggested that the master and pixel clocks be surrounded with ground shielding pins.
- C. In order to avoid the ground loop, it is recommended that the sensor analog ground be connected to sensor digital ground through a point or 0ohm resistor. Then the sensor digital ground should be connected to system ground through a point or a 0 ohm resistor.
- D. In order to reduce EM radiation, it is recommended that ground pins be assigned to the edge of the module connector.

3. Optical Lens Specification

3.1. Mechanical drawing of optical lens

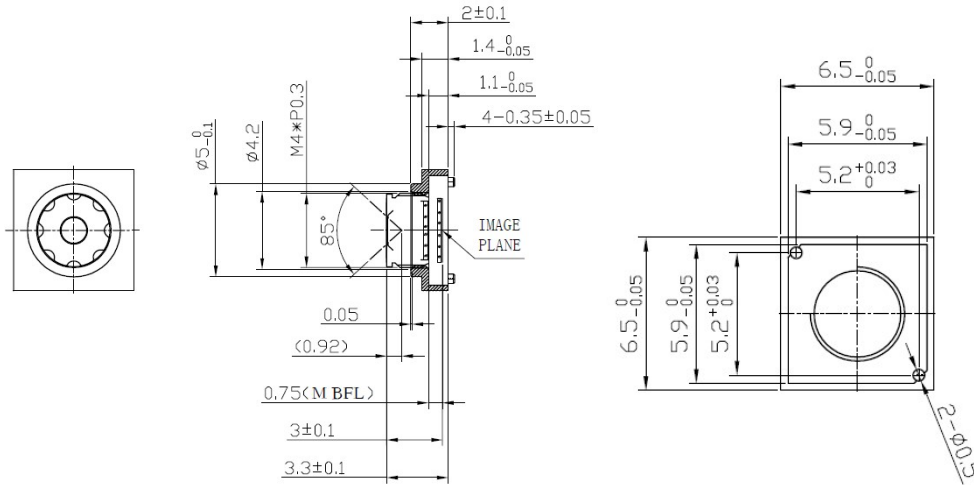

Figure 3.1: Mechanical drawing of optical lens

3.2. Specification of optical lens

Parameter	Spec.	
Construction	3P	
EFL	1.56 mm	
BFL	0.75 mm	
Image circle	φ3.0 mm	
F/No	2.4 ± 5%	
TV distortion	< 1.5%	
Field of view	Horizontal	70.1°
	Vertical	55.4°
	Diagonal	85.0°
Relative illumination	>33% at y=1.0 field	
Chief ray angle	< 28°	
Barrel size	M4 x P0.3	
Holder size	6.5mm x 6.5mm	
Total track (Barrel to image)	Y=3.0mm	

Table 3.1: Specification of optical lens

4. Image Quality Specification

No.	Test item	Diagram	Test condition	Standard
①	MTF		Test chart: 1/8 N Pattern chart Distance: 35cm Full image size	Center (0% field): ≥ 0.8 Corner (65% field): ≥ 0.6
②	Shading	 AOI: 32x32 pixel Shading ratio= $Y_{corner} (\text{Min.}) / Y_{center}$	Without ISP (raw image) Distance: 1cm Light condition: 1500 ± 300 lux, 5100 ± 300K	$\geq 30\%$
③	Blemish	 A: 324 pixel B: 324 pixel Block size: 9x9 pixel	Without ISP (raw image) Distance: 1cm Light condition: 1500 ± 300 lux, 5100 ± 300K	The luminance difference between each block and the adjacent block should be less than 3%
④	Defect pixel	Dark pixel defect	The sensor is illuminated to midlevel: ~ 400 LSBs to 700 LSBs.	Within a color plane, each pixel is compared to the mean of the neighboring 40 x 40 pixels. If the pixel value is 40 percent or more below the mean, it is considered a dark pixel defect.
		Bright pixel defect	The sensor is illuminated to midlevel: ~ 400 LSBs to 700 LSBs. (Analog gain = 1; exposure time = 10ms)	Within a color plane, each pixel is compared to the mean of the neighboring 40 x 40 pixels. If the pixel value is 40 percent or more above the mean, it is considered a dark pixel defect.
		Bright cluster Defect no.: 10	By "Bright Pixel Defect" Result	The defects within each color plane are examined. If any two adjacent pixels that are considered bright pixel defects are detected, they are then defined as a bright cluster.
		Dark Cluster Defect No.: 10	By "Dark Pixel Defect" Result	The defects within a color plane are examined. If any two adjacent pixels that are considered dark pixel defects are detected, they are then defined as a dark cluster.

Table 4.1: Image quality specification

5. Reliability Test Conditions

(Reliability test quantity: 35 pcs)

No.	Test item	Test conditions	Judgement
①	High temperature test	60°C / 48Hrs	The difference of MTF(%) Center <=5 Corner(0.7f) <=10
②	High temperature & Humidity test	60°C / 90%RH / 48Hrs	
③	Low temperature test	-20°C / 48Hrs	
④	Thermal shock test (No-Operating)	-20°C / 30min~60°C / 30min (32 cycles)	
⑤	ESD test (No-Operating)	Contact discharge: ±2.0 KV / 10 times, to USB connector Human Body Mode	
⑥	Mechanical vibration test (No-Operating, No packaging)	5Hz~350Hz~500Hz 0.21 Grms. Vibrate X, Y, and Z axis, 60min per axis.	
⑦	Mechanical vibration test (No-Operating, packaging)	5Hz~55Hz; -6dB; Acc 3G, Vibrate X, Y, and Z axis, 60min per axis.	
⑧	Drop test (No-Operating, No packaging)	80cm height free fall for 10 times per unit base material: concrete floor	
⑨	Drop test (No-Operating, packaging)	100cm height free fall for 10 impacts per unit (1 corner, 3 edges, 6 faces) base material: concrete floor	

Table 5.1: Reliability test condition

Himax Imaging, Ltd. Confidential
Do Not Copy

6. Inspection Specification

6.1. Sampling plan

- MIL-STD-105E level single normal random sampling
- Defect classification and Acceptable Quality Level (AQL)

Parameter	Dimension / Appearance	Image function
AQL	0.65	0.4

6.2. Visual inspection method

- Lighting: the light level in QC station is 500~800 Lux
- Location: test sample should put in front of inspector for 30cm ± 5cm
- View angle: 90 ± 15 degree

6.3. Inspection item

- Appearance and dimension check
- Image function inspection

6.4. Remark

This standard is a general. If any special case (e.g. specified component... etc), it should be created a related standard and keep it was updated. If any Dept. or customer ahs special request, we will use this request temporarily until it was canceled by Dept. or customer.

Himax Imaging, Ltd.
Confidential
Do Not Copy

6.5. Appearance / Dimension check

Parameter	No.	Item	Spec.	Picture
Product outline	①	Please follow ME drawing	Please reference ME drawing	Please reference ME drawing
Product appearance	①	Lens glue overflow Barrel damaged	A. No protruded glue residue on the Lens/Barrel surface B. Barrel can be not damaged	This is not the correct model, Only for understanding
	②	Lens scratch	A. Length $\leq 0.5D$ of lens B. Can be not influence image	This is not the correct model, Only for understanding
	③	Barrel scatch	A. Length $\leq D$ B. Length $\geq 1/2D$ allow 2 places C. Can't be across center area	This is not the correct model, Only for understanding
	④	FPCA burr	< 0.2mm and can't make the outline dimension out of spec.	
	⑤	Barrel loose	Barrel loosed is unacceptable	 Confirmation method: use the clean needle to see if UV glue is cured completely.
	⑥	Holder mount gap	A. Can't make the outline dimension out of spec. B. Can't influence image	This is not the correct model, Only for understanding

Parameter	No.	Item	Spec.	Picture
	⑦	Solder mask damage	Circuit or inner material exposure is not acceptable	<p>This is not the correct model, Only for understanding</p>
	⑧	FPC dirty or glue residue	Length (or 2Radius) of the dirty or glue residue < 1/5 th3 smallest edge length	<p>This is not the correct model, Only for understanding</p>
	⑨	FPC printing	A. printing missing is NG B. printing should be no blurred	<p>This is not the correct model, Only for understanding.</p>
	⑩	Connector	A. No solder ball and no solder residue B. Pin oxidation is not acceptable C. Pin damaged is not acceptable D. Connector deformed and caused image problem is unacceptable	

Parameter	No.	Item	Spec.	Picture
	①	Mylar attached	A. Mylar missing is NG B. Mylar should be in the same direction (same as PCB indicator) C. Mylar is allowed to be shifted within a range of 45 degree; however, Mylar lift-up is unacceptable	This is not the correct model, Only for understanding.
	⑫	Product label	A. Label missing is NG, should be no peeling, bubble, or blurred B. Label is correct and clear and at right location	This is not the correct model, Only for understanding.
Package	①	Packing	A. Quantity check B. Packing material check C. Model mixing, material mixing D. Label is correct and clear and at right location E. Label should be no peeling, un-complete or blurred	
Function	①	Output	By visual Image not complete or no image is not acceptable	
	②	Abnormal image	By visual Image upside down, abnormal color or apart is unacceptable	
	③	Blurred image	By visual Blurred, shading or another special image is unacceptable	
Image quality	①	Resolution test	By test program Images in center and 4 corners should be clear to identify the lines	
	②	Shading test	By test program Ratio of darkest to center should be great than specified ratio. (without lens correction)	
	③	Blemish	Both visual inspection and test by program are unacceptable	
	④	Defect pixel	Depend on test program judgment (Defect pixel definition follow sensor outgoing spec.)	