

## 7 Cell Cluster Concentrator Optic - Part No. 263

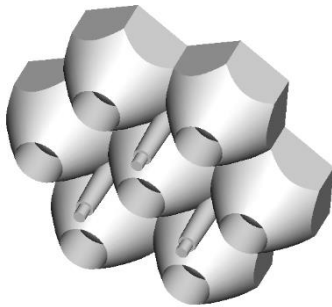

- Designed for low profile, high power, Lambertian LEDs
- High light collection efficiency of >85%
- Precision moulded in optical grade Polycarbonate for thermal stability and system durability
- Part of the Polymer Optics “Modular LED Optics”® range

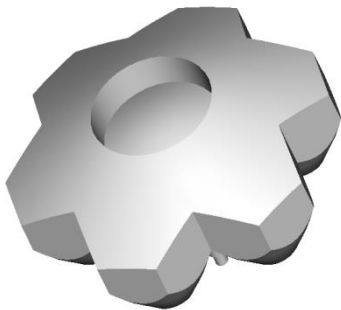

Typical dimensional tolerances  
to +/-0.2mm

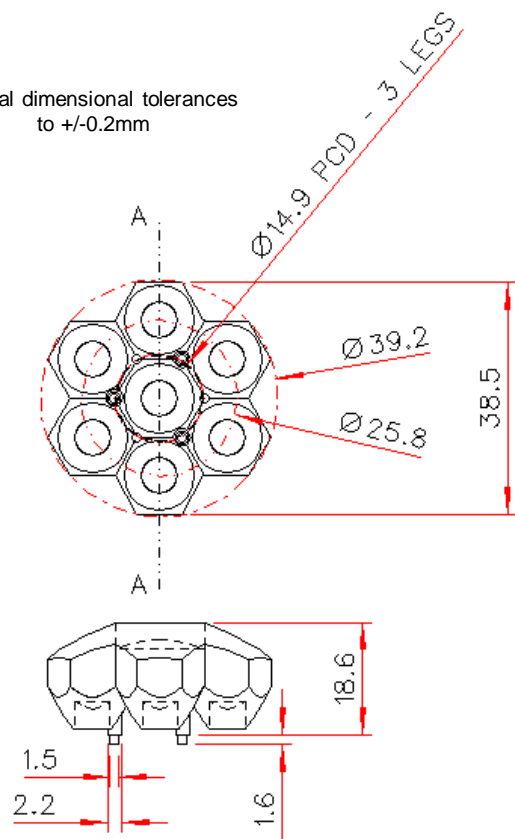

**Polymer Optics “Modular LED Optics”® design, based on a hexagonal format, allows maximum packing density and assembly flexibility**

In order to determine if the particular beam properties and performance of this optic are suitable for your application with your chosen LED type, POL suggests that you obtain samples from POL or their distributors for your own product testing, as properties may vary with different LED types.

Due to continuous product improvement, POL reserve the right to change specifications without notice.

© Copyright Polymer Optics Limited 2016

**7 Cell Cluster Concentrator Optic - Part No. 263**

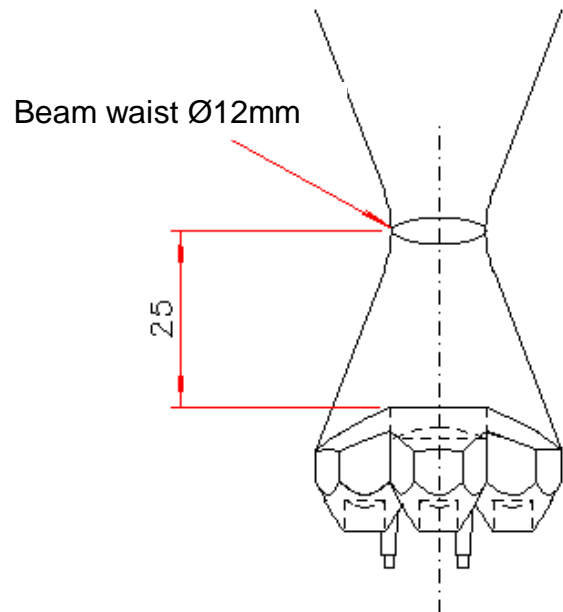

**Typical Applications:**

- Beam insertion into optical fibre bundles
- Beam insertion into edge of lightguides
- High intensity illumination of small objects for inspection and microscopy

In order to determine if the particular beam properties and performance of this optic are suitable for your application with your chosen LED type, POL suggests that you obtain samples from POL or their distributors for your own product testing, as properties may vary with different LED types.

Due to continuous product improvement, POL reserve the right to change specifications without notice.

© Copyright Polymer Optics Limited 2016