

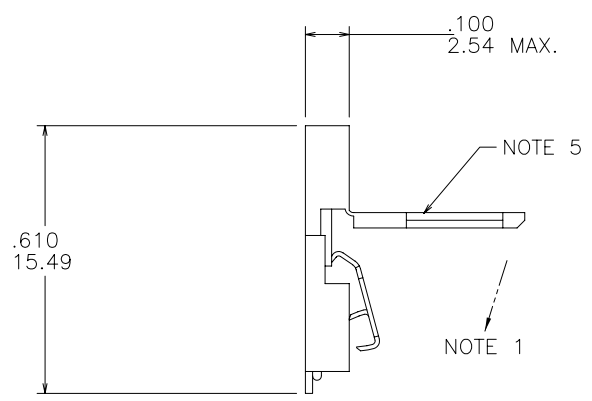

FCIconnect.com

Copyright FCI

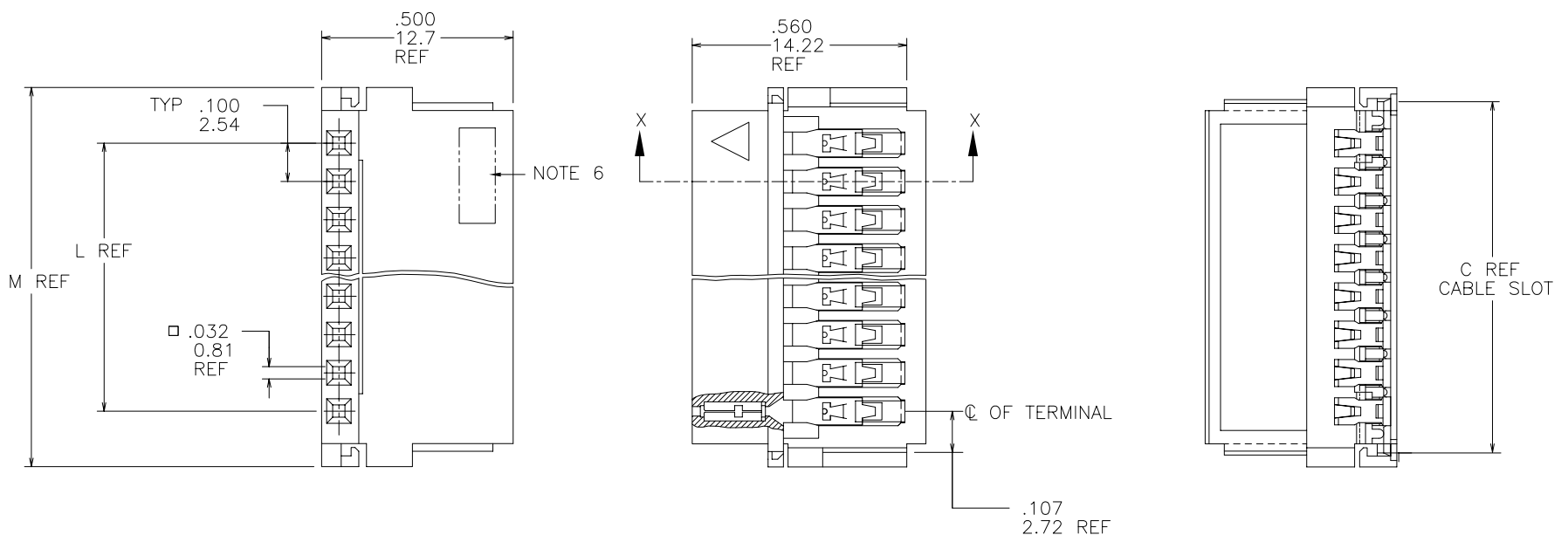

VIEW A-A
SCALE 8/1

mat'l. code				surface ISO 1302 ✓		tolerance ISO 406 ISO 1101		projection ⊕		product family CLINCHER			
tolerances unless otherwise specified				angles		linear		INCH/MM		title CLINCHER™ RECEPTACLE ASSEMBLY-THICK SPRING			
N	v50168	HTB	1/20/95			.XX±.01/.3				dwg no			sheet 1 of 6 size
P	v50221	HTB	2/7/95	0'±2'		.xxx±.005/.13		scale 1:2		67368			A3
R	v51478	HTB	12/1/95			.xxxx±.0020/.051				type			Product Customer Drawing
S	v60509	HTB	3/5/96	dr	L.SANDERS	12/8/94							
T	M05-0087	MHT	6/14/05	engr	T.HANNA	12/8/94							
U	M06-0233	AGS	6/13/06	chr	T.BREWBAKER	12/8/94							
V	M07-0170	MHT	3/30/07	appd	T.HANNA	12/8/94							
sheet	revision	V	V	V	V	V	V	V	V				
index	sheet	1	2	3	4	5	6						

form: A3



FCIconnect.com

Copyright FCI

1

2 3

4

5

6

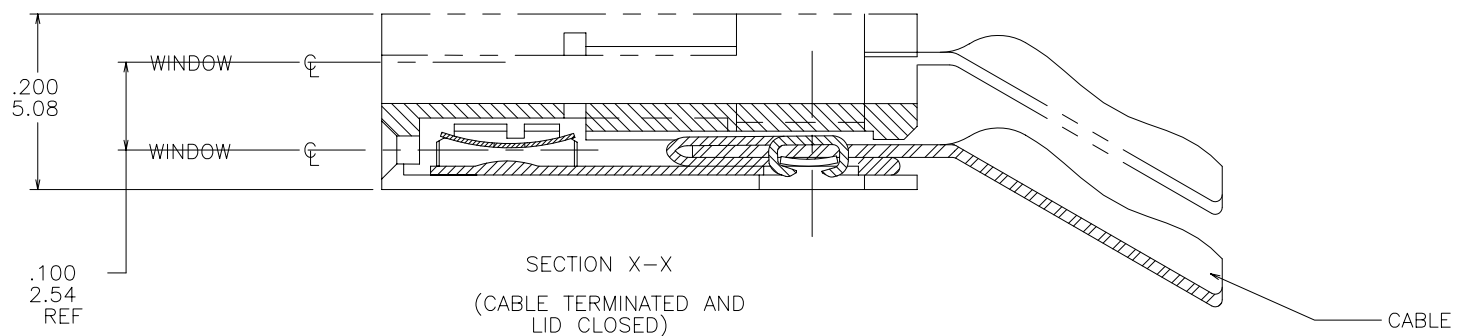
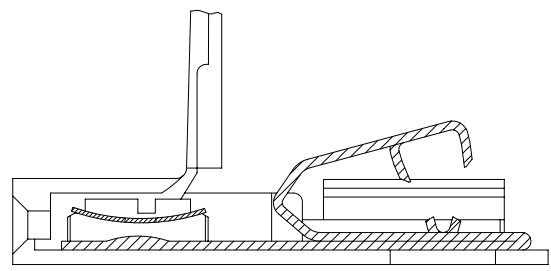

NOTES:

- ① LATCH SWINGS CLOSED AFTER TERMINATION MAINTAINING A MAX. OVER ALL HEIGHT OF .100/2.54.
- 2. MOLDING MAT'L,POLYPROPYLENE,FLAME RETARDANT PER UL 94V-0 COLOR:BLUE.
- 3. TERMINAL MAT'L: 1/2 HARD CU NI ALLOY. UNS-C 72500. PLATING: SEE TABULATION.
- 4. SPRING MAT'L: 1/2 HARD BE CU ALLOY, UNS-C17200. PLATING: SEE TABULATION.
- ⑤ CUSTOMER PART NUMBER.
- ⑥ LOGO WILL APPEAR IN THIS AREA.
- ⑦ ADD "LF" SUFFIX AT THE END OF PART NUMBER FOR LEAD FREE OPTION.
- ⑧ THIS PRODUCT MEETS EUROPEAN UNION DIRECTIVES AND OTHER COUNTRY REGULATION AS DESCRIBED IN GS-22-008.
- 9 THE PRODUCT IS NOT INTENDED TO BE EXPOSED TO A MANUFACTURING SOLDER PROCESS

PRODUCT NUMBER
67368-XXXLF

- LEAD FREE OPTION
NOTE 7,8
- NO OF POSITIONS
AND PLATING
- BASE PART NUMBER

mat'l. code		surface ISO 1302 ✓		tolerance ISO 406 ISO 1101		projection ⊕		product family CLINCHER	
ltr	ecn	no	dr	date		tolerances unless otherwise specified		title	
v						angles	linear	CLINCHER™ RECEPTACLE ASSEMBLY-THICK SPRING	
						0°±2'	.XX±.01/.3 .XXX±.005/.13 .XXXX±.0020/.051	INCH/MM scale 1:2	
			dr	L.SANDERS 12/8/94				dwg no sheet 2 of 6 size	
			enr	T.HANNA 12/8/94				67368 A3	
			chr	T.BREWBAKER 12/8/94				type Product Customer Drawing	
			appd	T.HANNA 12/8/94					
sheet index	revision sheet								

form: A3

1

2

3

4

5

6

PRODUCT NO. NOTE 7	NO.OF POS.	"L" REF.	"M" REF.	"C" REF.	PLATING
67368-001		U N A S S I G N E D			
-002	2	.100/2.54	.39/9.9	.315/8.00	TERM. PLATING 30u"/.76u MIN Au STRIPE IN BOX AREA.
-003	3	.200/5.08	.49/12.4	.415/10.54	
-004	4	.300/7.62	.59/14.9	.515/13.08	
-005	5	.400/10.16	.69/17.5	.615/15.62	
-006	6	.500/12.70	.79/20.0	.715/18.16	
-007	7	.600/15.24	.89/22.6	.815/20.70	
-008	8	.700/17.16	.99/25.1	.915/23.24	
-009	9	.800/20.32	1.09/27.0	1.015/25.78	
-010	10	.900/22.66	1.19/30.2	1.115/28.32	
-011	11	1.000/25.40	1.29/32.7	1.215/30.86	
-012	12	1.100/27.94	1.39/35.3	1.315/33.40	SPRING PLATING 5u"/0.13u MIN Au
-013	13	1.200/30.48	1.49/37.8	1.415/35.94	
-014	14	1.300/33.02	1.59/40.3	1.515/38.48	
-015	15	1.400/35.56	1.69/42.9	1.615/41.02	
-016	16	1.500/38.10	1.79/45.4	1.715/43.56	
-017	17	1.600/40.64	1.89/48.0	1.815/46.10	
-018	18	1.700/43.18	1.99/50.5	1.915/48.64	
-019	19	1.800/45.72	2.09/53.0	2.015/51.48	
-020	20	1.900/48.26	2.19/55.6	2.115/53.72	
-021	21	2.000/50.80	2.29/58.1	2.215/56.26	
-022	22	2.100/53.34	2.39/60.7	2.315/58.80	
-023	23	2.200/55.88	2.49/63.2	2.415/61.34	
-024	24	2.300/58.42	2.59/65.7	2.515/63.88	
-025	25	2.400/60.96	2.69/68.3	2.615/66.42	
-026	26	2.500/63.50	2.79/70.8	2.715/68.96	
-027	27	2.600/66.04	2.89/73.4	2.815/71.50	
-028	28	2.700/68.58	2.99/75.9	2.915/74.04	
-029	29	2.800/71.12	3.09/78.4	3.015/76.58	
-030	30	2.900/73.66	3.19/81.0	3.115/79.12	
-031	31	3.000/76.20	3.29/83.5	3.215/81.66	
67368-032	32	3.100/78.74	3.39/86.1	3.315/84.20	

TERM. PLATING
30u"/.76u MIN
Au STRIPE IN
BOX AREA.

SPRING PLATING
5u"/0.13u
MIN Au



Copyright FCI

mat'l. code		surface ISO 1302 <input checked="" type="checkbox"/>		tolerance ISO 406 ISO 1101		projection 		product family CLINCHER	
ltr	ecn no	dr	date	tolerances unless otherwise specified				title	
v				angles	linear	.XX±.01/.3 .xxx±.005/.13 .xxxx±.0020/.051		CLINCHER™ RECEPTACLE ASSEMBLY-THICK SPRING	
				0'±2'		scale 1:2		dwg no sheet 3 of 6 size	
				dr	L.SANDERS	12/8/94		67368 A3	
				enr	T.HANNA	12/8/94		type Product Customer Drawing	
				chr	T.BREWBAKER	12/8/94			
				appd	T.HANNA	12/8/94			
sheet index	revision sheet								

PRODUCT NO. NOTE 7	NO.OF POS.	"L" REF.	"M" REF.	"C" REF.	PLATING
67368-101	U N A S S I G N E D				
-102	2	.100/2.54	.39/9.9	.315/8.00	TERM. PLATING 100u"/2.54u THICK PURE TIN
-103	3	.200/5.08	.49/12.4	.415/10.54	
-104	4	.300/7.62	.59/14.9	.515/13.08	
-105	5	.400/10.16	.69/17.5	.615/15.62	
-106	6	.500/12.70	.79/20.0	.715/18.16	
-107	7	.600/15.24	.89/22.6	.815/20.70	
-108	8	.700/17.16	.99/25.1	.915/23.24	
-109	9	.800/20.32	1.09/27.0	1.015/25.78	
-110	10	.900/22.66	1.19/30.2	1.115/28.32	
-111	11	1.000/25.40	1.29/32.7	1.215/30.86	
-112	12	1.100/27.94	1.39/35.3	1.315/33.40	
-113	13	1.200/30.48	1.49/37.8	1.415/35.94	
-114	14	1.300/33.02	1.59/40.3	1.515/38.48	
-115	15	1.400/35.56	1.69/42.9	1.615/41.02	
-116	16	1.500/38.10	1.79/45.4	1.715/43.56	
-117	17	1.600/40.64	1.89/48.0	1.815/46.10	
-118	18	1.700/43.18	1.99/50.5	1.915/48.64	
-119	19	1.800/45.72	2.09/53.0	2.015/51.48	
-120	20	1.900/48.26	2.19/55.6	2.115/53.72	
-121	21	2.000/50.80	2.29/58.1	2.215/56.26	
-122	22	2.100/53.34	2.39/60.7	2.315/58.80	
-123	23	2.200/55.88	2.49/63.2	2.415/61.34	
-124	24	2.300/58.42	2.59/65.7	2.515/63.88	
-125	25	2.400/60.96	2.69/68.3	2.615/66.42	
-126	26	2.500/63.50	2.79/70.8	2.715/68.96	
-127	27	2.600/66.04	2.89/73.4	2.815/71.50	
-128	28	2.700/68.58	2.99/75.9	2.915/74.04	
-129	29	2.800/71.12	3.09/78.4	3.015/76.58	
-130	30	2.900/73.66	3.19/81.0	3.115/79.12	
-131	31	3.000/76.20	3.29/83.5	3.215/81.66	
67368-132	32	3.100/78.74	3.39/86.1	3.315/84.20	
					SPRING PLATING 30u"/0.76u PURE TIN



Copyright FCI

mat'l. code		surface ISO 1302 ✓	tolerance ISO 406 ISO 1101	projection 	product family CLINCHER
ltr	ecn no	dr	date	tolerances unless otherwise specified	title
v				linear .XX±.01/.3 angles .xxx±.005/.13 0'±2' .xxxx±.0020/.051	CLINCHER™ RECEPTACLE ASSEMBLY-THICK SPRING
				scale 1:2	dwg no sheet 4 of 6 size
					67368 A3
					type Product Customer Drawing
sheet index	revision sheet				

PRODUCT NO. NOTE 7	NO.OF POS.	"L" REF.	"M" REF.	"C" REF.	PLATING
67368-201					U N A S S I G N E D
-202					U N A S S I G N E D
-203					U N A S S I G N E D
-204					U N A S S I G N E D
-205					U N A S S I G N E D
-206					U N A S S I G N E D
-207					U N A S S I G N E D
-208	8	.700/17.16	.99/25.1	.915/23.24	TERM. PLATING 30u"/.76 MIN Au STRIPE IN BOX AREA.
-209	9	.800/20.32	1.09/27.0	1.015/25.78	
-210	10	.900/22.66	1.19/30.2	1.115/28.32	
-211	11	1.000/25.40	1.29/32.7	1.215/30.86	
-212	12	1.100/27.94	1.39/35.3	1.315/33.40	
-213	13	1.200/30.48	1.49/37.8	1.415/35.94	
-214	14	1.300/33.02	1.59/40.3	1.515/38.48	
-215	15	1.400/35.56	1.69/42.9	1.615/41.02	
-216	16	1.500/38.10	1.79/45.4	1.715/43.56	
-217	17	1.600/40.64	1.89/48.0	1.815/46.10	
-218	18	1.700/43.18	1.99/50.5	1.915/48.64	
-219	19	1.800/45.72	2.09/53.0	2.015/51.48	
-220	20	1.900/48.26	2.19/55.6	2.115/53.72	
-221	21	2.000/50.80	2.29/58.1	2.215/56.26	
-222	22	2.100/53.34	2.39/60.7	2.315/58.80	
-223	23	2.200/55.88	2.49/63.2	2.415/61.34	
-224	24	2.300/58.42	2.59/65.7	2.515/63.88	
-225	25	2.400/60.96	2.69/68.3	2.615/66.42	
-226	26	2.500/63.50	2.79/70.8	2.715/68.96	
-227	27	2.600/66.04	2.89/73.4	2.815/71.50	
-228	28	2.700/68.58	2.99/75.9	2.915/74.04	
-229	29	2.800/71.12	3.09/78.4	3.015/76.58	
-230	30	2.900/73.66	3.19/81.0	3.115/79.12	
-231	31	3.000/76.20	3.29/83.5	3.215/81.66	
67368-232	32	3.100/78.74	3.39/86.1	3.315/84.20	
					SPRING PLATING 20u"/.51u MIN Au

mat'l. code		surface ISO 1302 ✓		tolerance ISO 406 ISO 1101		projection ⊕		product family CLINCHER	
ltr	ecn no	dr	date	tolerances unless otherwise specified		INCH/MM		title	
v				angles	linear	.XX±.01/.3 .xxx±.005/.13 .xxxx±.0020/.051		CLINCHER™ RECEPTACLE ASSEMBLY-THICK SPRING	
				0'±2'		scale 1:2		dwg no sheet 5 of 6 size	
				dr	L.SANDERS	12/8/94		67368 A3	
				enr	T.HANNA	12/8/94		FCJ	
				chr	T.BREWBAKER	12/8/94		type Product Customer Drawing	
				appd	T.HANNA	12/8/94			
sheet index	revision sheet								

Copyright FCI
 FCIconnect.com

PRODUCT NO NOTE 7	NO.OF POS.	"L" REF.	"M" REF.	"C" REF.	PLATING	CUSTOMER P/N NOTE 5
67368-201-MIL						
-202-MIL						
-203-MIL						
-204-MIL						
-205-MIL						
-206-MIL						
-207-MIL						
-208-MIL	8	.700/17.16	.99/25.1	.915/23.24	TERM. PLATING 30u"/.76u MIN Au STRIPE IN BOX AREA.	503020-8
-209-MIL	9	.800/20.32	1.09/27.0	1.015/25.78		-9
-210-MIL	10	.900/22.66	1.19/30.2	1.115/28.32		-10
-211-MIL	11	1.000/25.40	1.29/32.7	1.215/30.86		-11
-212-MIL	12	1.100/27.94	1.39/35.3	1.315/33.40		-12
-213-MIL	13	1.200/30.48	1.49/37.8	1.415/35.94		-13
-214-MIL	14	1.300/33.02	1.59/40.3	1.515/38.48		-14
-215-MIL	15	1.400/35.56	1.69/42.9	1.615/41.02		-15
-216-MIL	16	1.500/38.10	1.79/45.4	1.715/43.56		-16
-217-MIL	17	1.600/40.64	1.89/48.0	1.815/46.10		-17
-218-MIL	18	1.700/43.18	1.99/50.5	1.915/48.64	-18	
-219-MIL	19	1.800/45.72	2.09/53.0	2.015/51.48	-19	
-220-MIL	20	1.900/48.26	2.19/55.6	2.115/53.72	-20	
-221-MIL	21	2.000/50.80	2.29/58.1	2.215/56.26	-21	
-222-MIL	22	2.100/53.34	2.39/60.7	2.315/58.80	-22	
-223-MIL	23	2.200/55.88	2.49/63.2	2.415/61.34	-23	
-224-MIL	24	2.300/58.42	2.59/65.7	2.515/63.88	-24	
-225-MIL	25	2.400/60.96	2.69/68.3	2.615/66.42	-25	
-226-MIL	26	2.500/63.50	2.79/70.8	2.715/68.96	-26	
-227-MIL	27	2.600/66.04	2.89/73.4	2.815/71.50	-27	
-228-MIL	28	2.700/68.58	2.99/75.9	2.915/74.04	-28	
-229-MIL	29	2.800/71.12	3.09/78.4	3.015/76.58	-29	
-230-MIL	30	2.900/73.66	3.19/81.0	3.115/79.12	-30	
-231-MIL	31	3.000/76.20	3.29/83.5	3.215/81.66	-31	
67368-232-MIL	32	3.100/78.74	3.39/86.1	3.315/84.20		503020-32

SPRING PLATING
20u"/.51u
MIN Au



Copyright FCI

mat'l. code		surface ISO 1302 <input checked="" type="checkbox"/>		tolerance ISO 406 ISO 1101		projection 		product family CLINCHER	
ltr	ecn no	dr	date	tolerances unless otherwise specified				title	
v				angles	linear	.XX±.01/.3		CLINCHER™ RECEPTACLE ASSEMBLY-THICK SPRING	
				0'±2'		.xxx±.005/.13		dwg no	
						.xxxx±.0020/.051		sheet 6 of 6 size	
				dr	L.SANDERS	12/8/94		67368	
				enr	T.HANNA	12/8/94		A3	
				chr	T.BREWBAKER	12/8/94		type	
				appd	T.HANNA	12/8/94		Product Customer Drawing	
sheet index	revision sheet								