



SPECIFICATIONS

Model	Speed Range m/s	Max Absorption Energy J(kgf·m)	Max Equivalent Mass kg (kgf)
FA-122C4-C	0.1~0.7	1.0(0.10)	7.5(7.5)

Max Drag N (kgf)	Absorption Energy per min. J/min(kgf·m/min)	Max Cycle Rate cycle/min	Rod Cap Color
294(30)	5.0(0.5)	5	Green

COMMON SPECIFICATIONS

Stroke	mm	12
Extension Force	N(kgf)	2.45(0.25) or less
Operating Temperature	C°	-10~50
Mass	g	15
Main Unit Material		Resin

PRECAUTIONS FOR USE

- Do not use this product without carefully reading the attached owner's manual.
- Use with an external stopper.
- Ensure that sufficient mounting strength is secured for this product. (As a guideline, it should be 2 to 3 times the maximum drag listed in the catalogue.)
- Do not turn the oil inlet screw located at the bottom of the main unit.
- 2 or more of this product can be used in parallel.
- Do not use this product in a vacuum or a location where it may come in contact with oil.
- Ensure that an eccentric load is not applied to the soft absorber. (Allowable eccentric angle: within $\pm 2.5^\circ$)
- Do not over-tighten the main unit and nuts. Please use the tightening torque (1.5N·m) listed in the owner's manual. If anchoring the absorber against the $\phi 14.6$ unit, please use a tightening torque of 1.0N·m.

OPTIONAL PARTS

Muting cap OP-090-M12B/C/D

Model
OP-090-M12B
OP-090-M12C
OP-090-M12D

B : Black
C : White
D : Gray

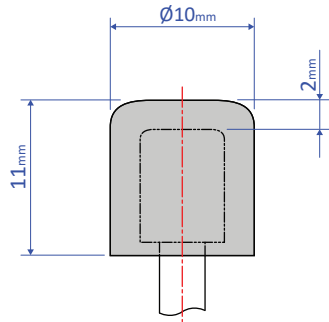

Material : Elastomer

- A muting cap reduces the collision noise
- To use, place it over a rod cap in the FA-1212C series
- Stroke length is 11mm

Small hexagon nut M12B

Model
M12B

- It is ideal for tight spaces, as it is smaller than the conventional hexagon nuts.

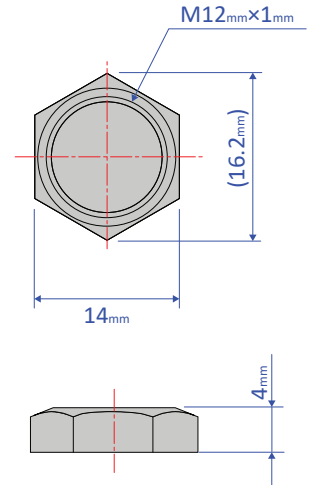

Standard nuts are sold separately as well

Applicable Models	Model
FA-1212C	FA-1212C nut