

Features

- ESD/Surge Protection for 1 Line with Unidirectional
- Provide ESD protection for each line to **IEC 61000-4-2 (ESD) $\pm 30\text{kV}$ (air / contact)**
IEC 61000-4-5 (Lightning) 20A (8/20 μs)
- Suitable for, **24V and below**, operating voltage applications
- Small package saves board space
- Protect one I/O line or one power line
- Fast turn-on and low clamping voltage
- Solid-state silicon-avalanche and active circuit triggering technology
- **Green part**
- **AEC-Q101 qualified**

Applications

- Power line protection
- Power Manager System
- Automotive
- Portable Devices
- Cellular Handsets and Accessories
- Notebooks, desktops, and servers
- Peripherals

Description

AZ9424-01G is a design which includes a unidirectional surge rated clamping cell to protect one power line, or one control line, or one low speed data line in an electronic system. The AZ9424-01G has been specifically designed to protect sensitive components which are

connected to power and control lines from over-voltage damage caused by Electrostatic Discharging (ESD), Lightning, and Cable Discharge Event (CDE).

AZ9424-01G is a unique design which includes proprietary clamping cell in a single package. During transient conditions, the proprietary clamping cell prevents over-voltage on the power line or control/data lines, protecting any downstream components.

AZ9424-01G may be used to meet the ESD immunity requirements of IEC 61000-4-2, Level 4 ($\pm 15\text{kV}$ air, $\pm 8\text{kV}$ contact discharge).

Circuit Diagram / Pin Configuration

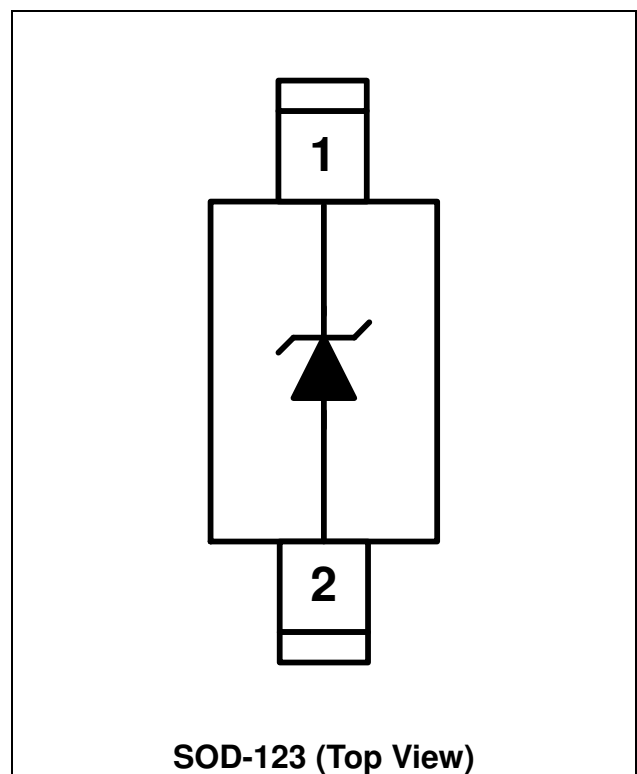



SPECIFICATIONS

ABSOLUTE MAXIMUM RATINGS			
PARAMETER	SYMBOL	RATING	UNITS
Peak Pulse Current (tp =8/20μs)	I _{PP}	20	A
Operating Supply Voltage (pin-1 to pin-2)	V _{DC}	26.4	V
Pin-1 to pin-2 ESD per IEC 61000-4-2 (Air)	V _{ESD-1}	±30	kV
Pin-1 to pin-2 ESD per IEC 61000-4-2 (Contact)	V _{ESD-2}	±30	
Lead Soldering Temperature	T _{SOL}	260 (10 sec.)	°C
Operating Temperature	T _{OP}	-55 to +125	°C
Storage Temperature	T _{STO}	-55 to +150	°C

ELECTRICAL CHARACTERISTICS						
PARAMETER	SYMBOL	CONDITIONS	MINI	TYP	MAX	UNITS
Reverse Stand-Off Voltage	V _{RWM}	Pin-1 to pin-2, T=25 °C.			24	V
Reverse Leakage Current	I _{Leak}	V _{RWM} = 24V, T=25 °C, pin-1 to pin-2.			1	μA
Reverse Breakdown Voltage	V _{BV}	I _{BV} = 1mA, T=25 °C, pin-1 to pin-2.	26.7		32.7	V
Forward Voltage	V _F	I _F = 15mA, T=25 °C, pin-2 to pin-1.	0.4		1.2	V
Surge Clamping Voltage	V _{CL-surge}	I _{PP} =5A, tp=8/20μs, T=25 °C, pin-1 to pin-2.		30		V
ESD Clamping Voltage (Note 1)	V _{clamp}	IEC 61000-4-2 +8kV (I _{TLP} = 16A), Contact mode, T=25 °C, pin-1 to pin-2.		31		V
ESD Dynamic Turn-on Resistance	R _{dynamic}	IEC 61000-4-2 0~+8kV, T=25 °C, Contact mode, pin-1 to pin-2.		0.2		Ω
Channel Input Capacitance	C _{IN}	V _R = 0V, f = 1MHz, T=25 °C, pin-1 to pin-2.		455	520	pF

Note 1: ESD Clamping Voltage was measured by Transmission Line Pulsing (TLP) System.

TLP conditions: Z₀= 50Ω, t_p= 100ns, t_r= 1ns.

Typical Characteristics

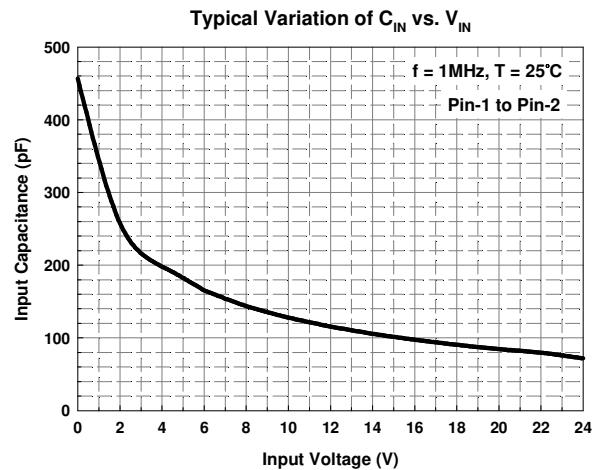
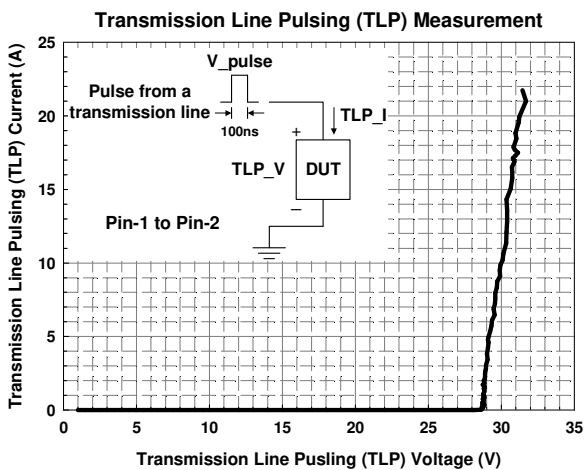
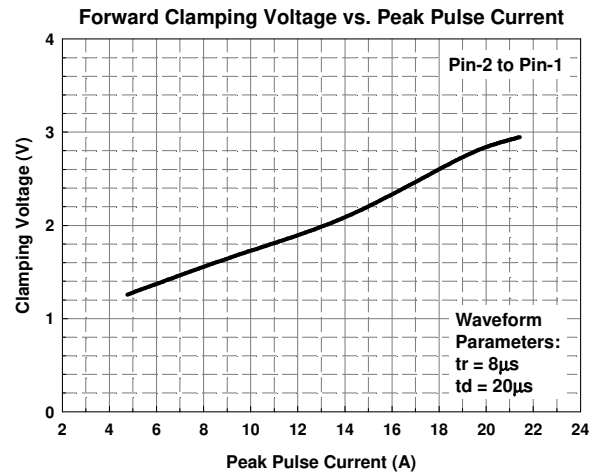
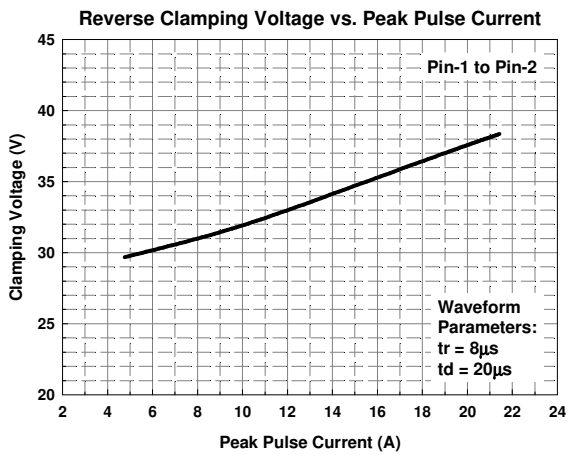



Applications Information

The AZ9424-01G is designed to protect one line against system ESD/Lightning pulses by clamping them to an acceptable reference.

The usage of the AZ9424-01G is shown in Fig. 1. Protected lines, such as data lines, control lines, or power lines, are connected at pin 1. The pin 2 should be connected directly to a ground plane on the board. All path lengths connected to the pins of AZ9424-01G should be kept as short as possible to minimize parasitic inductance in the board traces.

In order to obtain enough suppression of ESD induced transient, good circuit board is critical. Thus, the following guidelines are recommended:

- Minimize the path length between the protected lines and the AZ9424-01G.
- Place the AZ9424-01G near the input terminals or connectors to restrict transient coupling.
- The ESD current return path to ground should be kept as short as possible.
- Use ground planes whenever possible.
- NEVER route critical signals near board edges and near the lines which the ESD transient easily injects to.

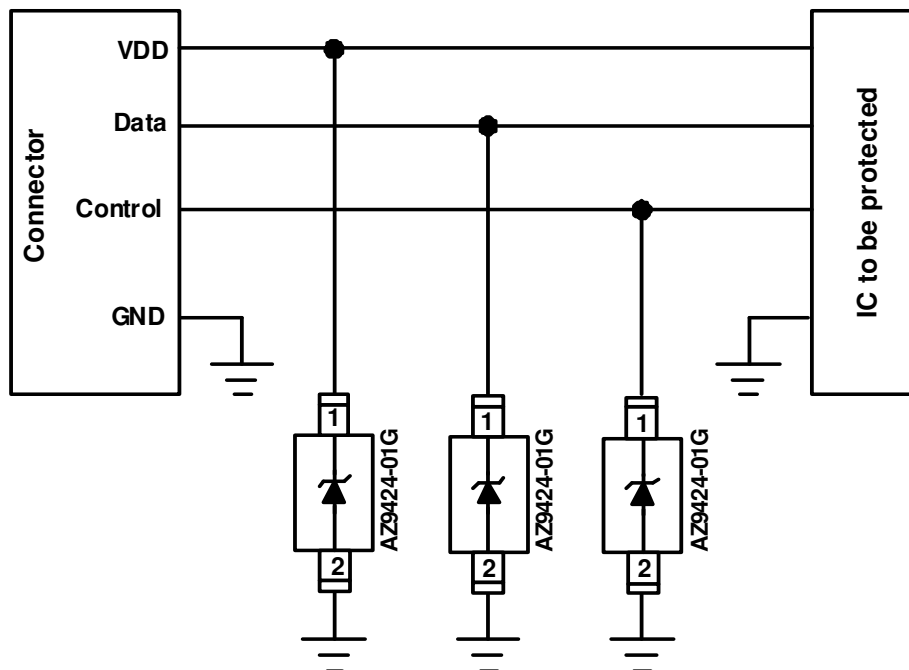

Fig. 1 ESD protection scheme by using AZ9424-01G.



Mechanical Details

SOD-123

PACKAGE DIAGRAMS

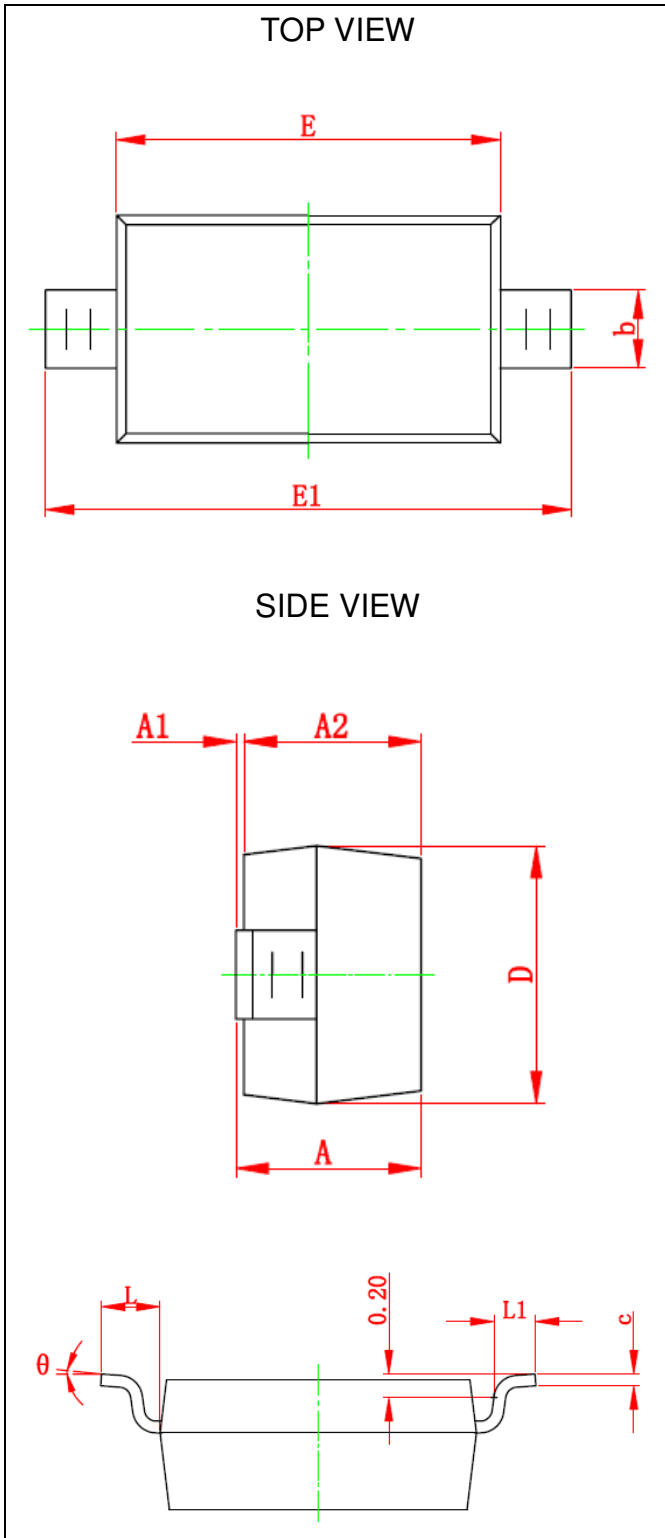

PACKAGE DIMENSIONS

Symbol	Millimeters		Inches	
	MIN.	MAX.	MIN.	MAX.
A	1.050	1.250	0.041	0.049
A1	0.000	0.100	0.000	0.004
A2	1.050	1.150	0.041	0.045
b	0.450	0.650	0.018	0.026
c	0.080	0.150	0.003	0.006
D	1.500	1.700	0.059	0.067
E	2.600	2.800	0.102	0.110
E1	3.550	3.850	0.140	0.152
L	0.500 REF		0.020 REF	
L1	0.250	0.450	0.010	0.018
θ	0°	8°	0°	8°

LAND LAYOUT

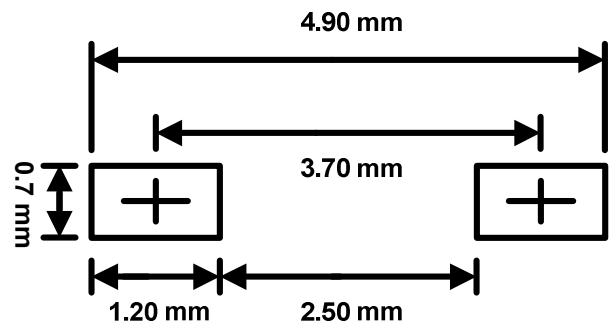

Notes:

This LAND LAYOUT is for reference purposes only. Please consult your manufacturing partners to ensure your company's PCB design guidelines are met.



MARKING CODE

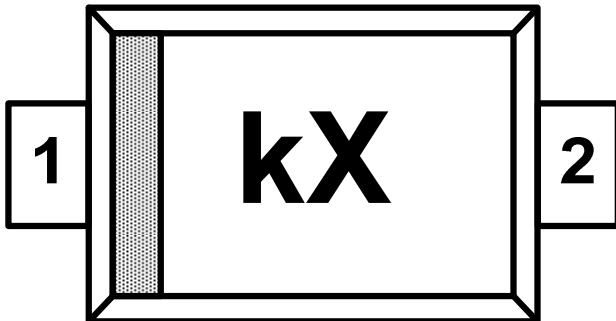

k = Device Code
X = Date Code

Part Number	Marking Code
AZ9424-01G.R7G (Green Part)	kX

Note. Green means Pb-free, RoHS, and Halogen free compliant.

Ordering Information

PN#	Material	Type	Reel size	MOQ	MOQ/internal box	MOQ/carton
AZ9424-01G.R7G	Green	T/R	7 inch	3,000/reel	4 reels = 12,000/box	6 boxes = 72,000/carton

Revision History

Revision	Modification Description
Revision 2016/11/11	Preliminary Release.
Revision 2017/05/15	Formal Release.