



SCCS028B - December 1987 - Revised September 2001

16-Bit Buffers/Line Drivers

Features

- I_{off} supports partial-power-down mode operation
- Edge-rate control circuitry for significantly improved noise characteristics
- Typical output skew < 250 ps
- ESD > 2000V
- TSSOP (19.6-mil pitch) and SSOP (25-mil pitch) packages
- Industrial temperature range of -40°C to $+85^{\circ}\text{C}$
- $V_{CC} = 5\text{V} \pm 10\%$

CY74FCT16244T Features:

- 64 mA sink current, 32 mA source current
- Typical V_{OLP} (ground bounce) < 1.0V at $V_{CC} = 5\text{V}$, $T_A = 25^{\circ}\text{C}$

CY74FCT162244T Features:

- Balanced output drivers: 24 mA
- Reduced system switching noise
- Typical V_{OLP} (ground bounce) < 0.6V at $V_{CC} = 5\text{V}$, $T_A = 25^{\circ}\text{C}$

CY74FCT162H244T Features:

- Bus hold on data inputs
- Eliminates the need for external pull-up or pull-down resistors

Functional Description

These 16-bit buffers/line drivers are designed for use in memory driver, clock driver, or other bus interface applications, where high-speed and low power are required. With flow-through pinout and small shrink packaging board layout is simplified. The three-state controls are designed to allow 4-bit, 8-bit or combined 16-bit operation.

This device is fully specified for partial-power-down applications using I_{off} . The I_{off} circuitry disables the outputs, preventing damaging current backflow through the device when it is powered down.

The CY74FCT16244T is ideally suited for driving high-capacitance loads and low-impedance backplanes.

The CY74FCT162244T has 24-mA balanced output drivers with current limiting resistors in the outputs. This reduces the need for external terminating resistors and provides for minimal undershoot and reduced ground bounce. The CY74FCT162244T is ideal for driving transmission lines.

The CY74FCT162H244T is a 24-mA balanced output part that has "bus hold" on the data inputs. The device retains the input's last state whenever the input goes to high impedance. This eliminates the need for pull-up/down resistors and prevents floating inputs.

Logic Block Diagrams CY74FCT16244T, CY74FCT162244T, CY74FCT162H244T

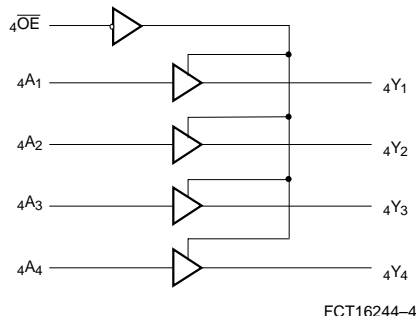
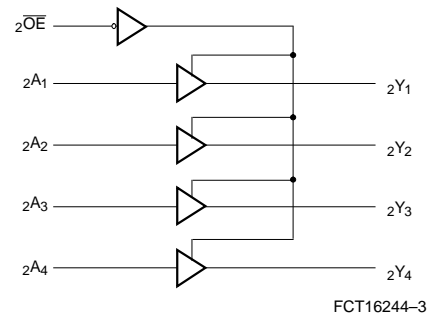
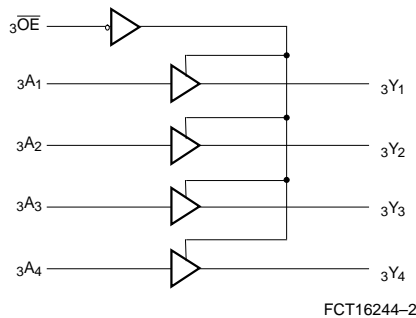
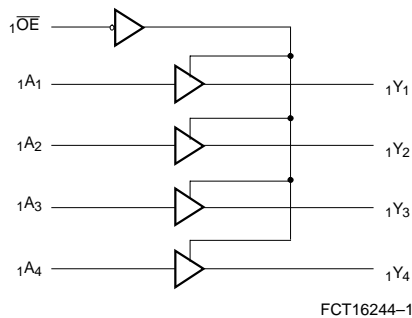

Pin Configuration

SSOP/TSSOP Top View

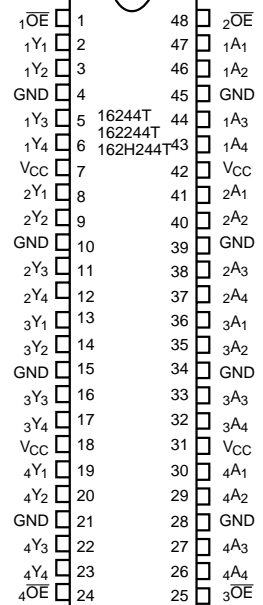

Pin Description

Name	Description
\overline{OE}	Three-State Output Enable Inputs (Active LOW)
A	Data Inputs ^[1]
Y	Three-State Outputs

Function Table^[2]

Inputs		Outputs
\overline{OE}	A	Y
L	L	L
L	H	H
H	X	Z

Maximum Ratings^[3,4]

(Above which the useful life may be impaired. For user guidelines, not tested.)

Storage Temperature.....	-55°C to +125°C
Ambient Temperature with Power Applied.....	-55°C to +125°C
DC Input Voltage	-0.5V to +7.0V
DC Output Voltage.....	-0.5V to +7.0V
DC Output Current (Maximum Sink Current/Pin)	-60 to +120 mA
Power Dissipation	1.0W
Static Discharge Voltage.....	>2001V (per MIL-STD-883, Method 3015)

Ordering Range

Range	Ambient Temperature	V _{CC}
Industrial	- 40°C to +85°C	5V ± 10%

Notes:

1. On CY74FCT162H244T these pins have "bus hold."
2. H = HIGH Voltage Level. L = LOW Voltage Level. X = Don't Care. Z = High Importance.
3. Operation beyond the limits set forth may impair the useful life of the device. Unless otherwise noted, these limits are over the operating free-air temperature range.
4. Unused inputs must always be connected to an appropriate logic voltage level, preferably either V_{CC} or ground.

Electrical Characteristics Over the Operating Range

Parameter	Description	Test Conditions	Min.	Typ. ^[5]	Max.	Unit
V _{IH}	Input HIGH Voltage		2.0			V
V _{IL}	Input LOW Voltage				0.8	V
V _H	Input Hysteresis ^[6]			100		mV
V _{IK}	Input Clamp Diode Voltage	V _{CC} =Min., I _{IN} =-18 mA		-0.7	-1.2	V
I _{IH}	Input HIGH Current	Standard	V _{CC} =Max., V _I =V _{CC}		±1	μA
		Bus Hold		±100		
I _{IL}	Input LOW Current	Standard	V _{CC} =Max., V _I =GND		±1	μA
		Bus Hold		±100		
I _{BBH} I _{BBL}	Bus Hold Sustain Current on Bus Hold Input ^[7]	V _{CC} =Min.	V _I =2.0V	-50		μA
			V _I =0.8V	+50		
I _{BHHO} I _{BHLO}	Bus Hold Overdrive Current on Bus Hold Input ^[7]	V _{CC} =Max., V _I =1.5V			TBD	mA
I _{OZH}	High Impedance Output Current (Three-State Output pins)	V _{CC} =Max., V _{OUT} =2.7V			±1	μA
I _{OZL}	High Impedance Output Current (Three-State Output pins)	V _{CC} =Max., V _{OUT} =0.5V			±1	μA
I _{OS}	Short Circuit Current ^[8]	V _{CC} =Max., V _{OUT} =GND	-80	-140	-200	mA
I _O	Output Drive Current ^[8]	V _{CC} =Max., V _{OUT} =2.5V	-50		-180	mA
I _{OFF}	Power-Off Disable	V _{CC} =0V, V _{OUT} ≤4.5V ^[9]			±1	μA

Output Drive Characteristics for CY74FCT16244T

Parameter	Description	Test Conditions	Min.	Typ. ^[5]	Max.	Unit
V _{OH}	Output HIGH Voltage	V _{CC} =Min., I _{OH} =-3 mA	2.5	3.5		V
		V _{CC} =Min., I _{OH} =-15 mA	2.4	3.5		V
		V _{CC} =Min., I _{OH} =-32 mA	2.0	3.0		V
V _{OL}	Output LOW Voltage	V _{CC} =Min., I _{OL} =64 mA		0.2	0.55	V

Output Drive Characteristics for CY74FCT162244T, CY74FCT162H244T

Parameter	Description	Test Conditions	Min.	Typ. ^[5]	Max.	Unit
I _{ODL}	Output LOW Current ^[8]	V _{CC} =5V, V _{IN} =V _{IH} or V _{IL} , V _{OUT} =1.5V	60	115	150	mA
I _{ODH}	Output HIGH Current ^[8]	V _{CC} =5V, V _{IN} =V _{IH} or V _{IL} , V _{OUT} =1.5V	-60	-115	-150	mA
V _{OH}	Output HIGH Voltage	V _{CC} =Min., I _{OH} =-24 mA	2.4	3.3		V
V _{OL}	Output LOW Voltage	V _{CC} =Min., I _{OL} =24 mA		0.3	0.55	V

Notes:

5. Typical values are at V_{CC}=5.0V, T_A = +25°C ambient.
6. This parameter is specified but not tested.
7. Pins with bus hold are described in Pin Description.
8. Not more than one output should be shorted at a time. Duration of short should not exceed one second. The use of high-speed test apparatus and/or sample and hold techniques are preferable in order to minimize internal chip heating and more accurately reflect operational values. Otherwise prolonged shorting of a high output may raise the chip temperature well above normal and thereby cause invalid readings in other parametric tests. In any sequence of parameter tests, I_{OS} tests should be performed last.
9. Tested at +25°C.

Capacitance^[6]($T_A = +25^\circ\text{C}$, $f = 1.0\text{ MHz}$)

Parameter	Description	Test Conditions	Typ. ^[5]	Max.	Unit
C_{IN}	Input Capacitance	$V_{IN} = 0V$	4.5	6.0	pF
C_{OUT}	Output Capacitance	$V_{OUT} = 0V$	5.5	8.0	pF

Power Supply Characteristics

Parameter	Description	Test Conditions	Typ. ^[5]	Max.	Unit	
I_{CC}	Quiescent Power Supply Current	$V_{CC} = \text{Max.}$ $V_{IN} \leq 0.2V$, $V_{IN} \leq V_{CC} - 0.2V$	5	500	μA	
ΔI_{CC}	Quiescent Power Supply Current (TTL inputs HIGH)	$V_{CC} = \text{Max.}$ $V_{IN} = 3.4V$ ^[10]	0.5	1.5	mA	
I_{CCD}	Dynamic Power Supply Current ^[11]	$V_{CC} = \text{Max.}$, One Input Toggling, 50% Duty Cycle, Outputs Open, $OE = \text{GND}$	60	100	$\mu\text{A}/\text{MHz}$	
I_C	Total Power Supply Current ^[12]	$V_{CC} = \text{Max.}$, $f_1 = 10\text{ MHz}$, 50% Duty Cycle, Outputs Open, One Bit Toggling, $OE = \text{GND}$	$V_{IN} = V_{CC}$ or $V_{IN} = \text{GND}$	0.6	1.5	mA
			$V_{IN} = 3.4V$ or $V_{IN} = \text{GND}$	0.9	2.3	mA
		$V_{CC} = \text{Max.}$, $f_1 = 2.5\text{ MHz}$, 50% Duty Cycle, Outputs Open, Sixteen Bits Toggling, $OE = \text{GND}$	$V_{IN} = V_{CC}$ or $V_{IN} = \text{GND}$	2.4	4.5 ^[13]	mA
			$V_{IN} = 3.4V$ or $V_{IN} = \text{GND}$	6.4	16.5 ^[13]	mA

Notes:

10. Per TTL driven input ($V_{IN} = 3.4V$); all other inputs at V_{CC} or GND.
11. This parameter is not directly testable, but is derived for use in Total Power Supply calculations.
12. $I_C = I_{CC} + \Delta I_{CC} D_H N_T + I_{CCD} (f_0/2 + f_1 N_1)$
 I_C = Total Power Supply Current
 I_{CC} = Quiescent Current with CMOS input levels
 ΔI_{CC} = Power Supply Current for a TTL HIGH input ($V_{IN} = 3.4V$)
 D_H = Duty Cycle for TTL inputs HIGH
 N_T = Number of TTL inputs at D_H
 I_{CCD} = Dynamic Current caused by an input transition pair (HLH or LHL)
 f_0 = Clock frequency for registered devices, otherwise zero
 f_1 = Input signal frequency
 N_1 = Number of inputs changing at f_1
 All currents are in milliamps and all frequencies are in megahertz.
13. Values for these conditions are examples of the I_{CC} formula. These limits are specified but not tested.

Switching Characteristics Over the Operating Range^[14]

Parameter	Description	CY74FCT16244T CY74FCT162244T		CY74FCT16244AT CY74FCT162244AT CY74FCT162H244AT		Unit	Fig. No. ^[15]
		Min.	Max.	Min.	Max.		
t _{PLH} t _{PHL}	Propagation Delay Data to Output	1.5	6.5	1.5	4.8	ns	1, 3
t _{PZH} t _{PZL}	Output Enable Time	1.5	8.0	1.5	6.2	ns	1, 7, 8
t _{PHZ} t _{PLZ}	Output Disable Time	1.5	7.0	1.5	5.6	ns	1, 7, 8
t _{SK(O)}	Output Skew ^[16]		0.5		0.5	ns	—

Switching Characteristics Over the Operating Range^[14] (continued)

Parameter	Description	CY74FCT16244CT CY74FCT162244CT CY74FCT162H244CT		Unit	Fig. No. ^[15]
		Min.	Max.		
t _{PLH} t _{PHL}	Propagation Delay Data to Output	1.5	4.1	ns	1, 3
t _{PZH} t _{PZL}	Output Enable Time	1.5	5.8	ns	1, 7, 8
t _{PHZ} t _{PLZ}	Output Disable Time	1.5	5.2	ns	1, 7, 8
t _{SK(O)}	Output Skew ^[16]		0.5	ns	—

Notes:

14. Minimum limits are specified but not tested on Propagation Delays.
15. See "Parameter Measurement Information" in the General Information section.
16. Skew between any two outputs of the same package switching in the same direction. This parameter is ensured by design.

Ordering Information CY74FCT16244

Speed (ns)	Ordering Code	Package Name	Package Type	Operating Range
4.1	CY74FCT16244CTPACT	Z48	48-Lead (240-Mil) TSSOP	Industrial
	CY74FCT16244CTPVC/PVCT	O48	48-Lead (300-Mil) SSOP	
4.8	CY74FCT16244ATPACT	Z48	48-Lead (240-Mil) TSSOP	Industrial
	CY74FCT16244ATPVC/PVCT	O48	48-Lead (300-Mil) SSOP	
6.5	CY74FCT16244TPACT	Z48	48-Lead (240-Mil) TSSOP	Industrial
	CY74FCT16244TPVC/PVCT	O48	48-Lead (300-Mil) SSOP	

Ordering Information CY74FCT162244

Speed (ns)	Ordering Code	Package Name	Package Type	Operating Range
4.1	74FCT162244CTPACT	Z48	48-Lead (240-Mil) TSSOP	Industrial
	CY74FCT162244CTPVC	O48	48-Lead (300-Mil) SSOP	
	74FCT162244CTPVCT	O48	48-Lead (300-Mil) SSOP	
4.8	74FCT162244ATPACT	Z48	48-Lead (240-Mil) TSSOP	Industrial
	CY74FCT162244ATPVC	O48	48-Lead (300-Mil) SSOP	
	74FCT162244ATPVCT	O48	48-Lead (300-Mil) SSOP	
6.5	CY74FCT162244TPACT	Z48	48-Lead (240-Mil) TSSOP	Industrial
	CY74FCT162244TPVC/PVCT	O48	48-Lead (300-Mil) SSOP	

Ordering Information CY74FCT162H244

Speed (ns)	Ordering Code	Package Name	Package Type	Operating Range
4.1	74FCT162H244CTPVC/PVCT	O48	48-Lead (300-Mil) SSOP	Industrial
4.8	74FCT162H244ATPACT	Z48	48-Lead (240-Mil) TSSOP	Industrial

Document #: 38-00396-C

Package Diagrams

48-Lead Shrunk Small Outline Package O48

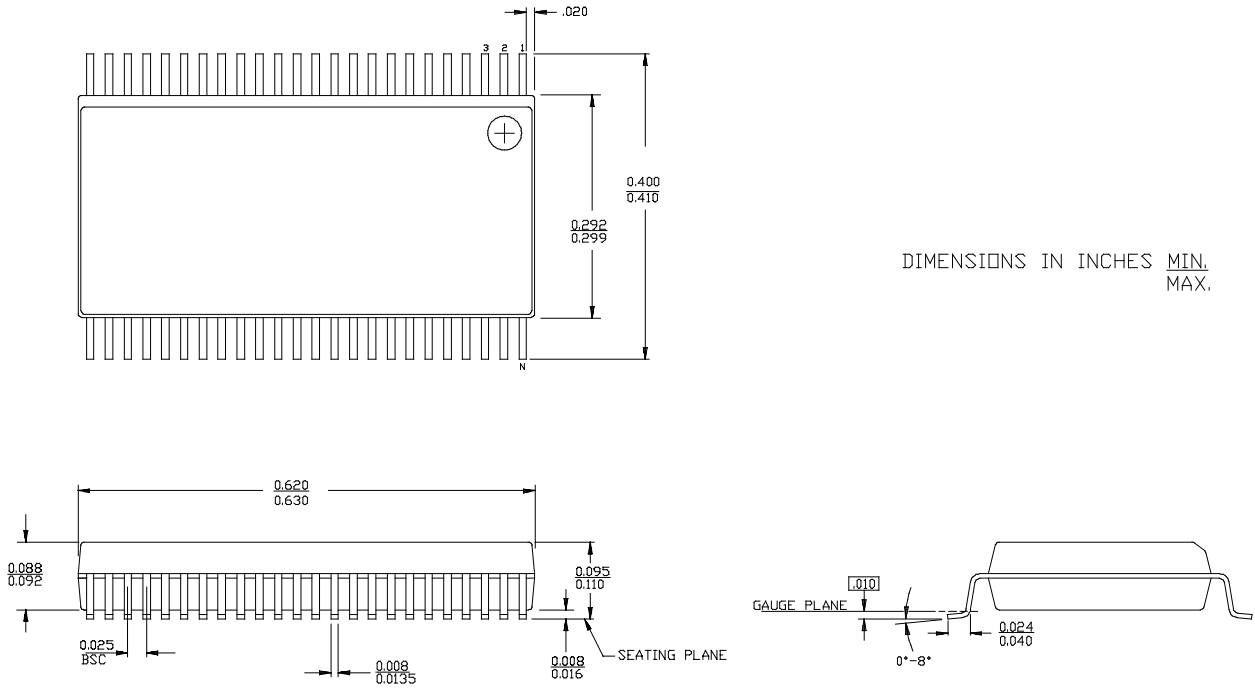

48-Lead Thin Shrunk Small Outline Package Z48

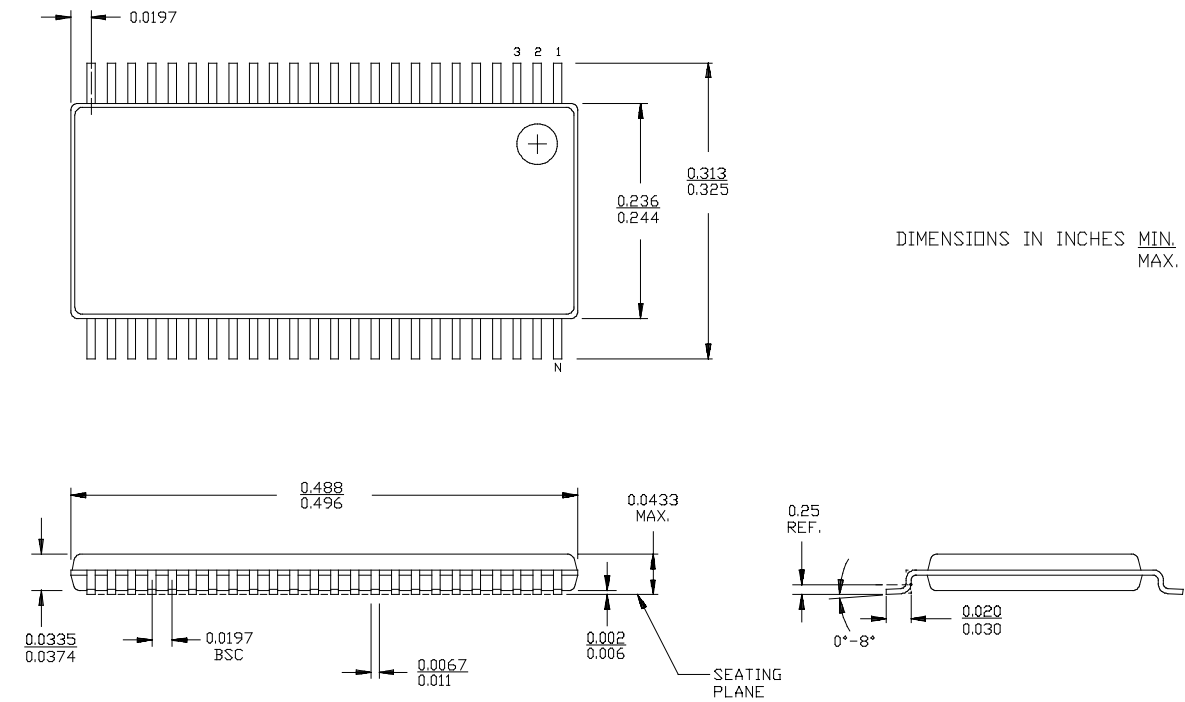

PACKAGING INFORMATION

Orderable Device	Status (1)	Package Type	Package Drawing	Pins	Package Qty	Eco Plan (2)	Lead/Ball Finish (6)	MSL Peak Temp (3)	Op Temp (°C)	Device Marking (4/5)	Samples
74FCT162244ATPACT	ACTIVE	TSSOP	DGG	48	2000	Green (RoHS & no Sb/Br)	CU NIPDAU	Level-1-260C-UNLIM	-40 to 85	FCT162244A	Samples
74FCT162244ATPVCG4	ACTIVE	SSOP	DL	48	25	Green (RoHS & no Sb/Br)	CU NIPDAU	Level-1-260C-UNLIM	-40 to 85	FCT162244A	Samples
74FCT162244ATPVCT	ACTIVE	SSOP	DL	48	1000	Green (RoHS & no Sb/Br)	CU NIPDAU	Level-1-260C-UNLIM	-40 to 85	FCT162244A	Samples
74FCT162244CTPACT	ACTIVE	TSSOP	DGG	48	2000	Green (RoHS & no Sb/Br)	CU NIPDAU	Level-1-260C-UNLIM	-40 to 85	FCT162244C	Samples
74FCT162244CTPVCG4	ACTIVE	SSOP	DL	48	25	Green (RoHS & no Sb/Br)	CU NIPDAU	Level-1-260C-UNLIM	-40 to 85	FCT162244C	Samples
74FCT162244CTPVCT	ACTIVE	SSOP	DL	48	1000	Green (RoHS & no Sb/Br)	CU NIPDAU	Level-1-260C-UNLIM	-40 to 85	FCT162244C	Samples
74FCT162244ETPACT	OBSOLETE	TSSOP	DGG	48		TBD	Call TI	Call TI	-40 to 85		
74FCT162244ETPVCT	OBSOLETE	SSOP	DL	48		TBD	Call TI	Call TI	-40 to 85		
74FCT162244TPVCG4	ACTIVE	SSOP	DL	48	25	Green (RoHS & no Sb/Br)	CU NIPDAU	Level-1-260C-UNLIM	-40 to 85	FCT162244	Samples
74FCT16244ATPVCG4	ACTIVE	SSOP	DL	48	25	Green (RoHS & no Sb/Br)	CU NIPDAU	Level-1-260C-UNLIM	-40 to 85	FCT16244A	Samples
74FCT16244TPACTG4	ACTIVE	TSSOP	DGG	48	2000	Green (RoHS & no Sb/Br)	CU NIPDAU	Level-1-260C-UNLIM	-40 to 85	FCT16244	Samples
74FCT162H244ATPACT	ACTIVE	TSSOP	DGG	48	2000	Green (RoHS & no Sb/Br)	CU NIPDAU	Level-1-260C-UNLIM	-40 to 85	FCT162H244A	Samples
74FCT162H244CTPVC	ACTIVE	SSOP	DL	48	25	Green (RoHS & no Sb/Br)	CU NIPDAU	Level-1-260C-UNLIM	-40 to 85	FCT162H244C	Samples
74FCT162H244CTPVCT	OBSOLETE	SSOP	DL	48		TBD	Call TI	Call TI	-40 to 85		
74FCT162H244ETPAC	OBSOLETE	TSSOP	DGG	48		TBD	Call TI	Call TI	-40 to 85		
74FCT162H244ETPACT	OBSOLETE	TSSOP	DGG	48		TBD	Call TI	Call TI	-40 to 85		
74FCT162H244ETPVC	OBSOLETE	SSOP	DL	48		TBD	Call TI	Call TI	-40 to 85		
74FCT162H244ETPVCT	OBSOLETE	SSOP	DL	48		TBD	Call TI	Call TI	-40 to 85		
CY74FCT162244ATPVC	ACTIVE	SSOP	DL	48	25	Green (RoHS & no Sb/Br)	CU NIPDAU	Level-1-260C-UNLIM	-40 to 85	FCT162244A	Samples
CY74FCT162244CTPVC	ACTIVE	SSOP	DL	48	25	Green (RoHS & no Sb/Br)	CU NIPDAU	Level-1-260C-UNLIM	-40 to 85	FCT162244C	Samples

Orderable Device	Status (1)	Package Type	Package Drawing	Pins	Package Qty	Eco Plan (2)	Lead/Ball Finish (6)	MSL Peak Temp (3)	Op Temp (°C)	Device Marking (4/5)	Samples
CY74FCT162244ETPAC	OBSOLETE	TSSOP	DGG	48		TBD	Call TI	Call TI	-40 to 85		
CY74FCT162244ETPVC	OBSOLETE	SSOP	DL	48		TBD	Call TI	Call TI	-40 to 85		
CY74FCT162244TPACT	ACTIVE	TSSOP	DGG	48	2000	Green (RoHS & no Sb/Br)	CU NIPDAU	Level-1-260C-UNLIM	-40 to 85	FCT162244	Samples
CY74FCT162244TPVC	ACTIVE	SSOP	DL	48	25	Green (RoHS & no Sb/Br)	CU NIPDAU	Level-1-260C-UNLIM	-40 to 85	FCT162244	Samples
CY74FCT162244TPVCT	ACTIVE	SSOP	DL	48	1000	Green (RoHS & no Sb/Br)	CU NIPDAU	Level-1-260C-UNLIM	-40 to 85	FCT162244	Samples
CY74FCT16244ATPACT	ACTIVE	TSSOP	DGG	48	2000	Green (RoHS & no Sb/Br)	CU NIPDAU	Level-1-260C-UNLIM	-40 to 85	FCT16244A	Samples
CY74FCT16244ATPVC	ACTIVE	SSOP	DL	48	25	Green (RoHS & no Sb/Br)	CU NIPDAU	Level-1-260C-UNLIM	-40 to 85	FCT16244A	Samples
CY74FCT16244CTPACT	ACTIVE	TSSOP	DGG	48	2000	Green (RoHS & no Sb/Br)	CU NIPDAU	Level-1-260C-UNLIM	-40 to 85	FCT16244C	Samples
CY74FCT16244CTPVC	ACTIVE	SSOP	DL	48	25	Green (RoHS & no Sb/Br)	CU NIPDAU	Level-1-260C-UNLIM	-40 to 85	FCT16244C	Samples
CY74FCT16244ETPAC	OBSOLETE	TSSOP	DGG	48		TBD	Call TI	Call TI	-40 to 85		
CY74FCT16244ETPACT	OBSOLETE	TSSOP	DGG	48		TBD	Call TI	Call TI	-40 to 85		
CY74FCT16244ETPVC	OBSOLETE	SSOP	DL	48		TBD	Call TI	Call TI	-40 to 85		
CY74FCT16244ETPVCT	OBSOLETE	SSOP	DL	48		TBD	Call TI	Call TI	-40 to 85		
CY74FCT16244TPACT	ACTIVE	TSSOP	DGG	48	2000	Green (RoHS & no Sb/Br)	CU NIPDAU	Level-1-260C-UNLIM	-40 to 85	FCT16244	Samples
CY74FCT16244TPVC	ACTIVE	SSOP	DL	48	25	Green (RoHS & no Sb/Br)	CU NIPDAU	Level-1-260C-UNLIM	-40 to 85	FCT16244	Samples
CY74FCT16244TPVCT	ACTIVE	SSOP	DL	48	1000	Green (RoHS & no Sb/Br)	CU NIPDAU	Level-1-260C-UNLIM	-40 to 85	FCT16244	Samples
FCT162H244CTPVCTG4	ACTIVE	SSOP	DL	48		TBD	Call TI	Call TI	-40 to 85		Samples

(1) The marketing status values are defined as follows:

ACTIVE: Product device recommended for new designs.

LIFEBUY: TI has announced that the device will be discontinued, and a lifetime-buy period is in effect.

NRND: Not recommended for new designs. Device is in production to support existing customers, but TI does not recommend using this part in a new design.

PREVIEW: Device has been announced but is not in production. Samples may or may not be available.

OBSOLETE: TI has discontinued the production of the device.

⁽²⁾ Eco Plan - The planned eco-friendly classification: Pb-Free (RoHS), Pb-Free (RoHS Exempt), or Green (RoHS & no Sb/Br) - please check <http://www.ti.com/productcontent> for the latest availability information and additional product content details.

TBD: The Pb-Free/Green conversion plan has not been defined.

Pb-Free (RoHS): TI's terms "Lead-Free" or "Pb-Free" mean semiconductor products that are compatible with the current RoHS requirements for all 6 substances, including the requirement that lead not exceed 0.1% by weight in homogeneous materials. Where designed to be soldered at high temperatures, TI Pb-Free products are suitable for use in specified lead-free processes.

Pb-Free (RoHS Exempt): This component has a RoHS exemption for either 1) lead-based flip-chip solder bumps used between the die and package, or 2) lead-based die adhesive used between the die and leadframe. The component is otherwise considered Pb-Free (RoHS compatible) as defined above.

Green (RoHS & no Sb/Br): TI defines "Green" to mean Pb-Free (RoHS compatible), and free of Bromine (Br) and Antimony (Sb) based flame retardants (Br or Sb do not exceed 0.1% by weight in homogeneous material)

⁽³⁾ MSL, Peak Temp. - The Moisture Sensitivity Level rating according to the JEDEC industry standard classifications, and peak solder temperature.

⁽⁴⁾ There may be additional marking, which relates to the logo, the lot trace code information, or the environmental category on the device.

⁽⁵⁾ Multiple Device Markings will be inside parentheses. Only one Device Marking contained in parentheses and separated by a "~" will appear on a device. If a line is indented then it is a continuation of the previous line and the two combined represent the entire Device Marking for that device.

⁽⁶⁾ Lead/Ball Finish - Orderable Devices may have multiple material finish options. Finish options are separated by a vertical ruled line. Lead/Ball Finish values may wrap to two lines if the finish value exceeds the maximum column width.

Important Information and Disclaimer: The information provided on this page represents TI's knowledge and belief as of the date that it is provided. TI bases its knowledge and belief on information provided by third parties, and makes no representation or warranty as to the accuracy of such information. Efforts are underway to better integrate information from third parties. TI has taken and continues to take reasonable steps to provide representative and accurate information but may not have conducted destructive testing or chemical analysis on incoming materials and chemicals. TI and TI suppliers consider certain information to be proprietary, and thus CAS numbers and other limited information may not be available for release.

In no event shall TI's liability arising out of such information exceed the total purchase price of the TI part(s) at issue in this document sold by TI to Customer on an annual basis.

TAPE AND REEL INFORMATION



QUADRANT ASSIGNMENTS FOR PIN 1 ORIENTATION IN TAPE



*All dimensions are nominal

Device	Package Type	Package Drawing	Pins	SPQ	Reel Diameter (mm)	Reel Width W1 (mm)	A0 (mm)	B0 (mm)	K0 (mm)	P1 (mm)	W (mm)	Pin1 Quadrant
74FCT162244ATPACT	TSSOP	DGG	48	2000	330.0	24.4	8.6	13.0	1.8	12.0	24.0	Q1
74FCT162244ATPVCT	SSOP	DL	48	1000	330.0	32.4	11.35	16.2	3.1	16.0	32.0	Q1
74FCT162244CTPACT	TSSOP	DGG	48	2000	330.0	24.4	8.6	13.0	1.8	12.0	24.0	Q1
74FCT162244CTPVCT	SSOP	DL	48	1000	330.0	32.4	11.35	16.2	3.1	16.0	32.0	Q1
74FCT162H244ATPACT	TSSOP	DGG	48	2000	330.0	24.4	8.6	13.0	1.8	12.0	24.0	Q1
CY74FCT162244TPACT	TSSOP	DGG	48	2000	330.0	24.4	8.6	13.0	1.8	12.0	24.0	Q1
CY74FCT162244TPVCT	SSOP	DL	48	1000	330.0	32.4	11.35	16.2	3.1	16.0	32.0	Q1
CY74FCT16244ATPACT	TSSOP	DGG	48	2000	330.0	24.4	8.6	13.0	1.8	12.0	24.0	Q1
CY74FCT16244CTPACT	TSSOP	DGG	48	2000	330.0	24.4	8.6	13.0	1.8	12.0	24.0	Q1
CY74FCT16244TPACT	TSSOP	DGG	48	2000	330.0	24.4	8.6	13.0	1.8	12.0	24.0	Q1
CY74FCT16244TPVCT	SSOP	DL	48	1000	330.0	32.4	11.35	16.2	3.1	16.0	32.0	Q1

TAPE AND REEL BOX DIMENSIONS

*All dimensions are nominal

Device	Package Type	Package Drawing	Pins	SPQ	Length (mm)	Width (mm)	Height (mm)
74FCT162244ATPACT	TSSOP	DGG	48	2000	367.0	367.0	45.0
74FCT162244ATPVCT	SSOP	DL	48	1000	367.0	367.0	55.0
74FCT162244CTPACT	TSSOP	DGG	48	2000	367.0	367.0	45.0
74FCT162244CTPVCT	SSOP	DL	48	1000	367.0	367.0	55.0
74FCT162H244ATPACT	TSSOP	DGG	48	2000	367.0	367.0	45.0
CY74FCT162244TPACT	TSSOP	DGG	48	2000	367.0	367.0	45.0
CY74FCT162244TPVCT	SSOP	DL	48	1000	367.0	367.0	55.0
CY74FCT16244ATPACT	TSSOP	DGG	48	2000	367.0	367.0	45.0
CY74FCT16244CTPACT	TSSOP	DGG	48	2000	367.0	367.0	45.0
CY74FCT16244TPACT	TSSOP	DGG	48	2000	367.0	367.0	45.0
CY74FCT16244TPVCT	SSOP	DL	48	1000	367.0	367.0	55.0

MECHANICAL DATA

DL (R-PDSO-G48)

PLASTIC SMALL-OUTLINE PACKAGE



- NOTES:
- All linear dimensions are in inches (millimeters).
 - This drawing is subject to change without notice.
 - Body dimensions do not include mold flash or protrusion not to exceed 0.006 (0,15).
 - Falls within JEDEC MO-118

PowerPAD is a trademark of Texas Instruments.

DGG (R-PDSO-G**)

PLASTIC SMALL-OUTLINE PACKAGE

48 PINS SHOWN



- NOTES: A. All linear dimensions are in millimeters.
 B. This drawing is subject to change without notice.
 C. Body dimensions do not include mold protrusion not to exceed 0,15.
 D. Falls within JEDEC MO-153

IMPORTANT NOTICE FOR TI DESIGN INFORMATION AND RESOURCES

Texas Instruments Incorporated ("TI") technical, application or other design advice, services or information, including, but not limited to, reference designs and materials relating to evaluation modules, (collectively, "TI Resources") are intended to assist designers who are developing applications that incorporate TI products; by downloading, accessing or using any particular TI Resource in any way, you (individually or, if you are acting on behalf of a company, your company) agree to use it solely for this purpose and subject to the terms of this Notice.

TI's provision of TI Resources does not expand or otherwise alter TI's applicable published warranties or warranty disclaimers for TI products, and no additional obligations or liabilities arise from TI providing such TI Resources. TI reserves the right to make corrections, enhancements, improvements and other changes to its TI Resources.

You understand and agree that you remain responsible for using your independent analysis, evaluation and judgment in designing your applications and that you have full and exclusive responsibility to assure the safety of your applications and compliance of your applications (and of all TI products used in or for your applications) with all applicable regulations, laws and other applicable requirements. You represent that, with respect to your applications, you have all the necessary expertise to create and implement safeguards that (1) anticipate dangerous consequences of failures, (2) monitor failures and their consequences, and (3) lessen the likelihood of failures that might cause harm and take appropriate actions. You agree that prior to using or distributing any applications that include TI products, you will thoroughly test such applications and the functionality of such TI products as used in such applications. TI has not conducted any testing other than that specifically described in the published documentation for a particular TI Resource.

You are authorized to use, copy and modify any individual TI Resource only in connection with the development of applications that include the TI product(s) identified in such TI Resource. NO OTHER LICENSE, EXPRESS OR IMPLIED, BY ESTOPPEL OR OTHERWISE TO ANY OTHER TI INTELLECTUAL PROPERTY RIGHT, AND NO LICENSE TO ANY TECHNOLOGY OR INTELLECTUAL PROPERTY RIGHT OF TI OR ANY THIRD PARTY IS GRANTED HEREIN, including but not limited to any patent right, copyright, mask work right, or other intellectual property right relating to any combination, machine, or process in which TI products or services are used. Information regarding or referencing third-party products or services does not constitute a license to use such products or services, or a warranty or endorsement thereof. Use of TI Resources may require a license from a third party under the patents or other intellectual property of the third party, or a license from TI under the patents or other intellectual property of TI.

TI RESOURCES ARE PROVIDED "AS IS" AND WITH ALL FAULTS. TI DISCLAIMS ALL OTHER WARRANTIES OR REPRESENTATIONS, EXPRESS OR IMPLIED, REGARDING TI RESOURCES OR USE THEREOF, INCLUDING BUT NOT LIMITED TO ACCURACY OR COMPLETENESS, TITLE, ANY EPIDEMIC FAILURE WARRANTY AND ANY IMPLIED WARRANTIES OF MERCHANTABILITY, FITNESS FOR A PARTICULAR PURPOSE, AND NON-INFRINGEMENT OF ANY THIRD PARTY INTELLECTUAL PROPERTY RIGHTS.

TI SHALL NOT BE LIABLE FOR AND SHALL NOT DEFEND OR INDEMNIFY YOU AGAINST ANY CLAIM, INCLUDING BUT NOT LIMITED TO ANY INFRINGEMENT CLAIM THAT RELATES TO OR IS BASED ON ANY COMBINATION OF PRODUCTS EVEN IF DESCRIBED IN TI RESOURCES OR OTHERWISE. IN NO EVENT SHALL TI BE LIABLE FOR ANY ACTUAL, DIRECT, SPECIAL, COLLATERAL, INDIRECT, PUNITIVE, INCIDENTAL, CONSEQUENTIAL OR EXEMPLARY DAMAGES IN CONNECTION WITH OR ARISING OUT OF TI RESOURCES OR USE THEREOF, AND REGARDLESS OF WHETHER TI HAS BEEN ADVISED OF THE POSSIBILITY OF SUCH DAMAGES.

You agree to fully indemnify TI and its representatives against any damages, costs, losses, and/or liabilities arising out of your non-compliance with the terms and provisions of this Notice.

This Notice applies to TI Resources. Additional terms apply to the use and purchase of certain types of materials, TI products and services. These include; without limitation, TI's standard terms for semiconductor products (<http://www.ti.com/sc/docs/stdterms.htm>), [evaluation modules](#), and [samples](http://www.ti.com/sc/docs/sampterm.htm) (<http://www.ti.com/sc/docs/sampterm.htm>).

Mailing Address: Texas Instruments, Post Office Box 655303, Dallas, Texas 75265
Copyright © 2017, Texas Instruments Incorporated