

Features

- Fast Switching Speed
- Ultra-Small Surface Mount Package
- For General Purpose Switching Applications
- High Conductance
- Available in Lead Free/RoHS Compliant Version (Note 4)

Mechanical Data

- Case: SOD-323
- Case Material: Molded Plastic. UL Flammability Classification Rating 94V-0
- Moisture Sensitivity: Level 1 per J-STD-020C
- Terminals: Solderable per MIL-STD-202, Method 208
- Also Available in Lead Free Plating (Matte Tin Finish annealed over Alloy 42 leadframe). Please See Ordering Information, Note 5, on Page 1
- Polarity: Cathode Band
- Marking: See Page 2
- Type Code: LG
- Ordering Information: See Below
- Weight: 0.006 grams (approximate)

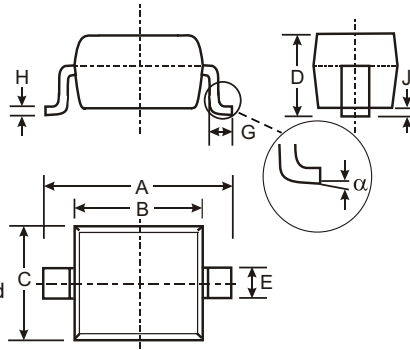

SOD-323		
Dim	Min	Max
A	2.30	2.70
B	1.60	1.80
C	1.20	1.40
D	1.05 Typical	
E	0.25	0.35
G	0.20	0.40
H	0.10	0.15
J	0.05 Typical	
α	0°	8°
All Dimensions in mm		

Maximum Ratings @ $T_A = 25^\circ\text{C}$ unless otherwise specified

Characteristic	Symbol	Value	Unit
Peak Repetitive Reverse Voltage Working Peak Reverse Voltage DC Blocking Voltage	V_{RRM} V_{RWM} V_R	45	V
RMS Reverse Voltage	$V_{R(RMS)}$	40	V
Forward Continuous Current (Note 1)	I_{FM}	100	mA
Forward Surge Current @ $t < 8.3\text{ms}$	I_{FSM}	1.0	A
Power Dissipation (Note 1)	P_d	200	mW
Thermal Resistance Junction to Ambient Air (Note 1)	$R_{\theta JA}$	500	$^\circ\text{C/W}$
Operating and Storage Temperature Range	T_j, T_{STG}	-40 to +125	$^\circ\text{C}$

Electrical Characteristics @ $T_A = 25^\circ\text{C}$ unless otherwise specified

Characteristic	Symbol	Min	Typ	Max	Unit	Test Condition
Reverse Breakdown Voltage (Note 2)	$V_{(BR)R}$	45	—	—	—	$I_R = 100\mu\text{A}$
Forward Voltage (Note 2)	V_F	—	370	450	mV	$I_F = 10\text{mA}$
Reverse Leakage Current (Note 2)	I_R	—	0.07	1.0	μA	$V_R = 10\text{V}$
Total Capacitance	C_T	—	6.0	—	pF	$V_R = 10\text{V}, f = 1.0\text{MHz}$

Ordering Information (Note 3)

Device	Packaging	Shipping
SDM10K45-7	SOD-323	3000/Tape & Reel

- Note: 1. Device mounted on FR-5 PCB 1.0 x 0.75 x 0.062 inch pad layout as shown on Diodes, Inc. suggested pad layout AP02001, which can be found on our website at <http://www.diodes.com/datasheets/ap02001.pdf>.
2. Short duration pulse test to minimize self-heating effect.
3. For packaging details, go to our website at <http://www.diodes.com/datasheets/ap02007.pdf>.
4. No purposefully added lead.
5. For Lead Free/RoHS Compliant version part number, please add "-F" suffix to the part number above. Example: SDM10K45-7-F.

Marking Information

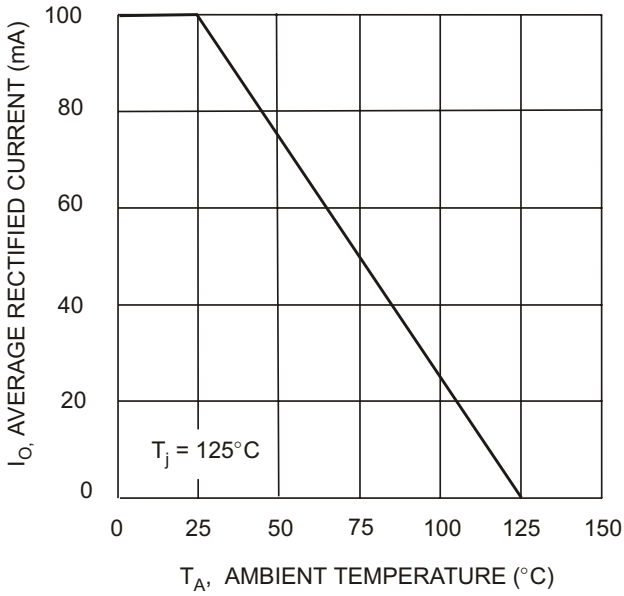
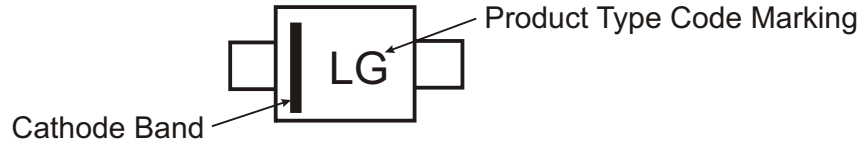

Fig. 1 Forward Current Derating Curve

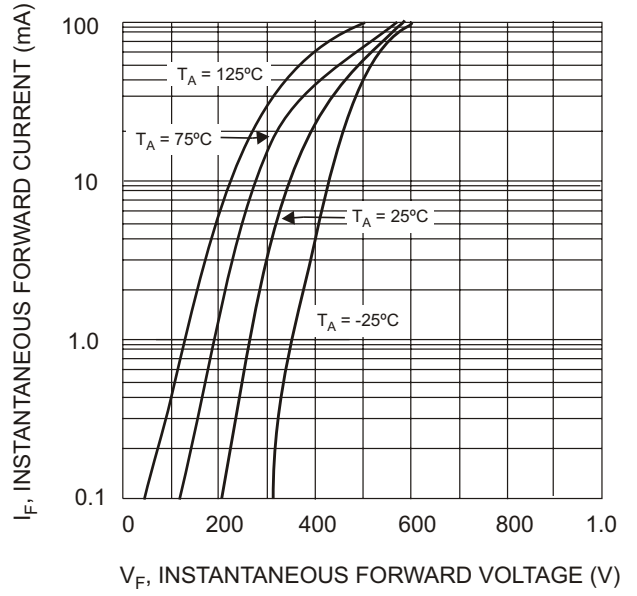

Fig. 2 Typical Forward Characteristics

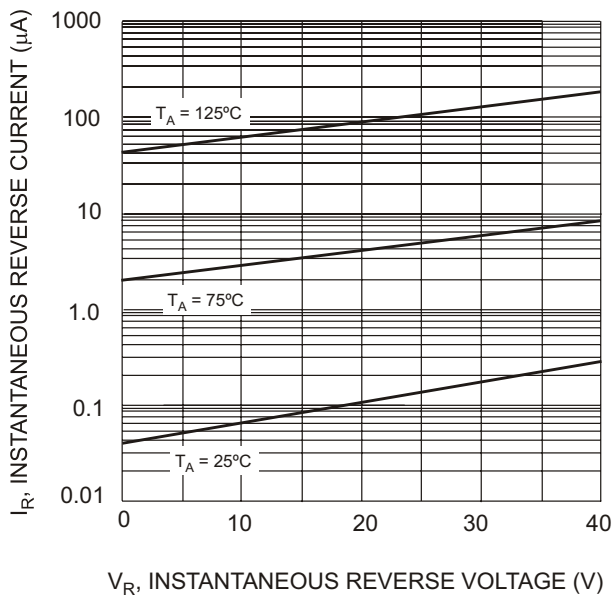

Fig. 3 Typical Reverse Characteristics

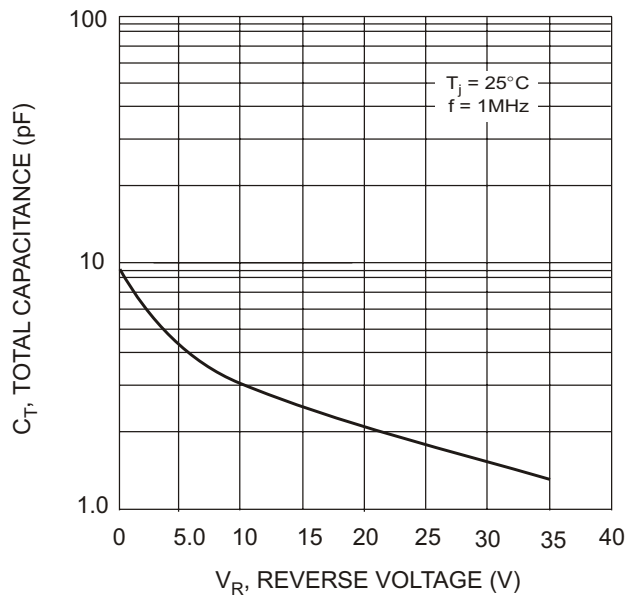

Fig. 4 Total Capacitance vs. Reverse Voltage