

# DKS-SOLDERBREAD-01-ND

A perfboard with a solderless breadboard format



\* Back side = Numbers are reversed to match the rows

## Specifications:

Plating:	ENIG (Nickel Plated Gold) Plated Through Hole (PTH)
Pitch:	0.1" (2.54mm)
Solder Hole Diameter:	0.04" (1.00mm)
Mounting Hole Diameter:	0.12" (3.00mm)
Size / Dimension:	1.90"L x 2.00"W (48.3mm x 50.8mm)
Board Thickness:	0.063" (1.60mm)
Material:	FR4 Epoxy Glass

Overall dimensions: Mounting holes are 3mm

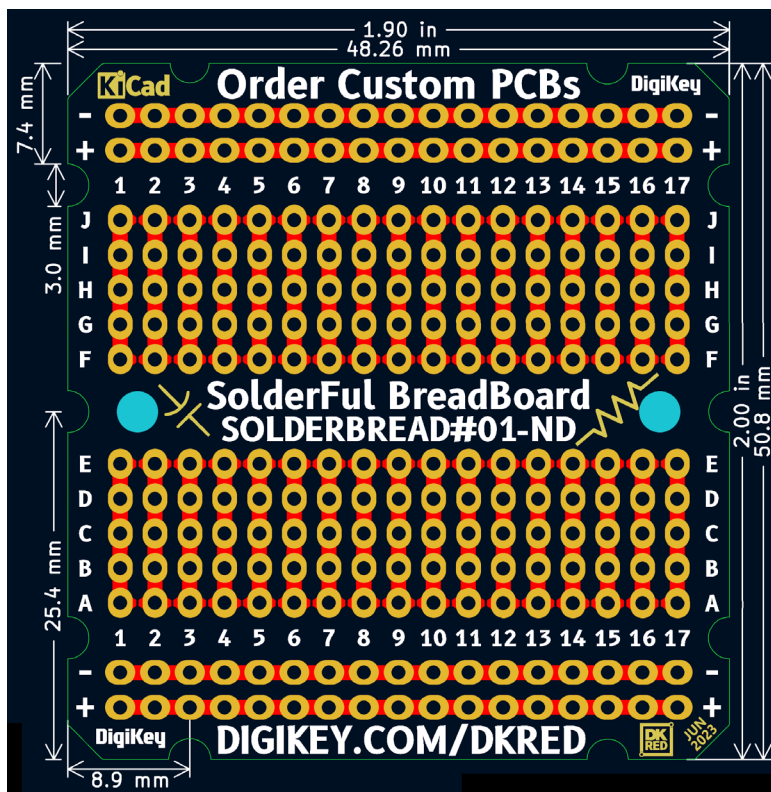

### Special pads for surface mount (SMT) 0201 and up

And for bridge neighboring nets at each end (scrape the mask off first)

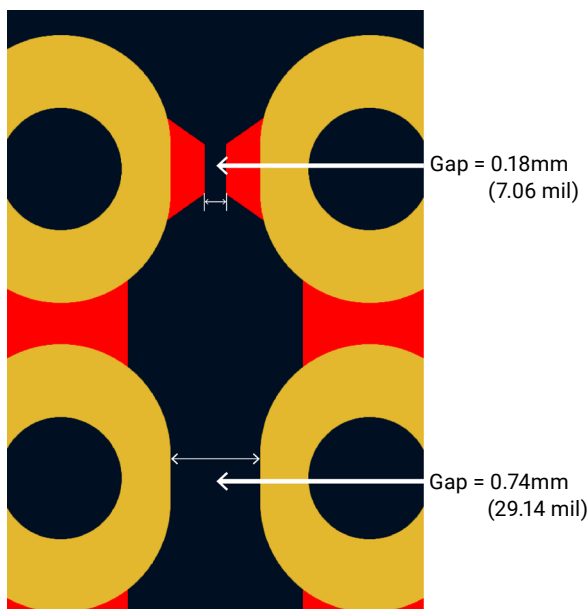

These blocks for reference

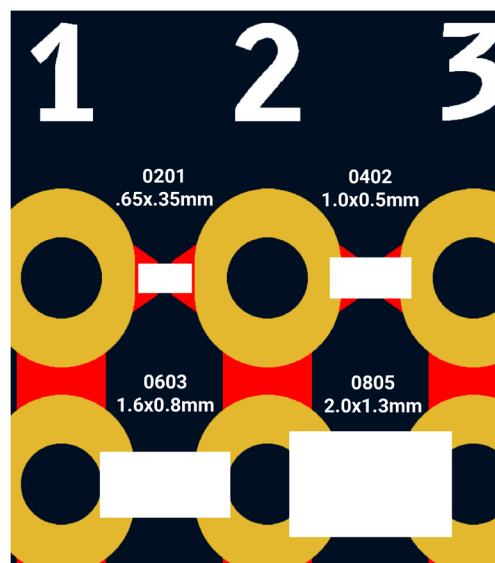

These LEDs were hand soldered as a test

Hand soldering 0201 parts should be avoided, but it can be done

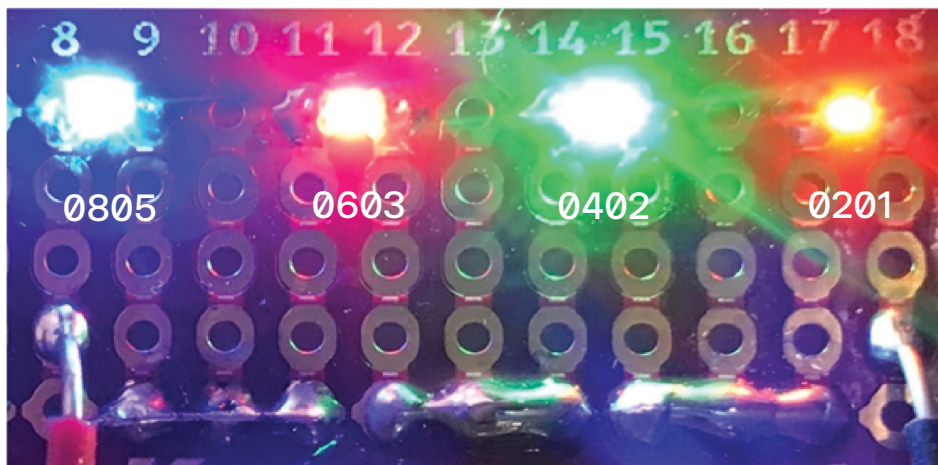

\* The LEDs were powered in series at 10 mA

Parts used:

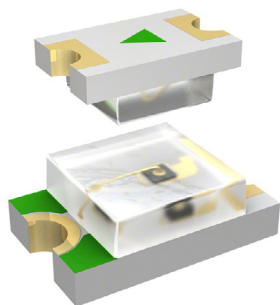

**0805 (2012 Metric)**

[732-4982-1-ND](#)

Blue – 3.2V (Typ) –  
2.00mm x 1.25mm



**0603 (1608 Metric)**

[3147-B1911USD-20D000114U1930CT-ND](#)

Red – 2V (Typ) –  
1.60mm x 0.80mm

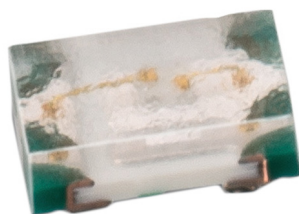

**0402 (1005 Metric)**

[732-11990-1-ND](#)

Green – 3.2V (Typ) –  
1.00mm x 0.50mm –  
Very bright, even at 1 mA

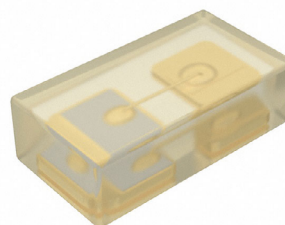

**0201 (0603 Metric)**

[754-2027-1-ND](#)

Orange – 2V (Typ) – 10mA  
– 0.65mm x 0.35mm

How to solder two terminal SMT parts:

1. Place your part on pads  
(0805 used here)

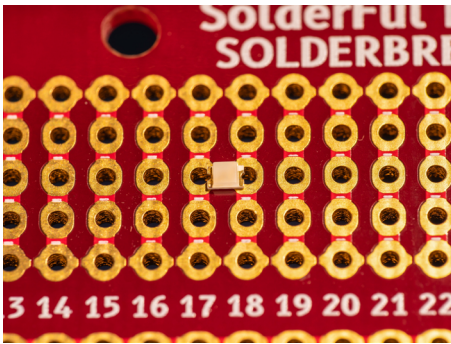

2. Add flux to one side of part  
and pad

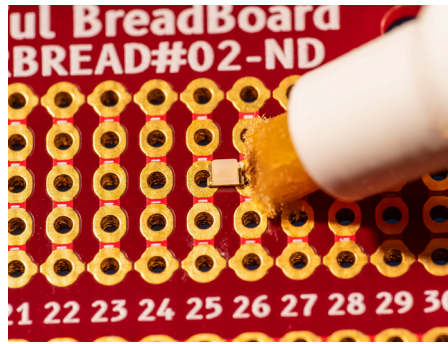

3. Place some solder on a pad



4. Add solder to your iron

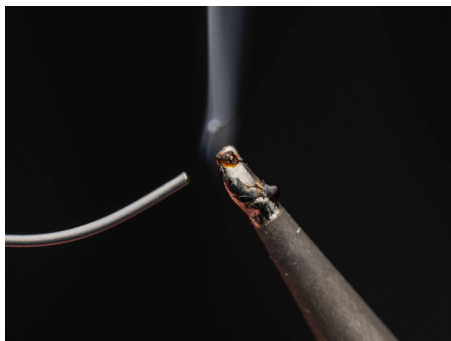

5. Hold the part with a tweezers  
and touch with the iron

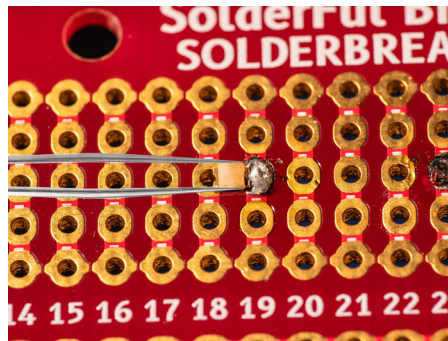

6. Now add solder to the  
other side

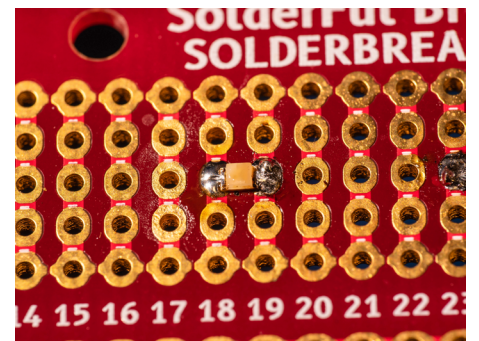

7. Testing the LED with a DMM  
on continuity check - success!



A big Thank You to [KiCad!](#)